

Note: The equipment shown in these drawings was only installed on cars with train-phone.

Pennsylvania Railroad class N5c cabin car, train-phone version

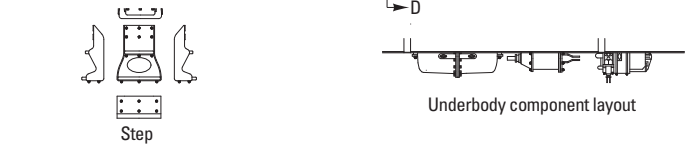

Ratio 1:87.1, HO scale
 To convert HO scale drawings to your scale copy at these percentages:
 N 54.4 percent
 S 136.1 percent
 O 181.4 percent

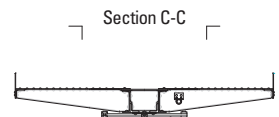
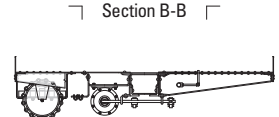
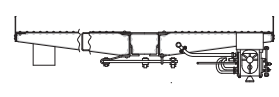
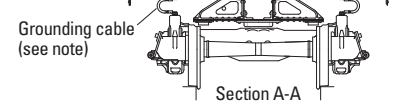
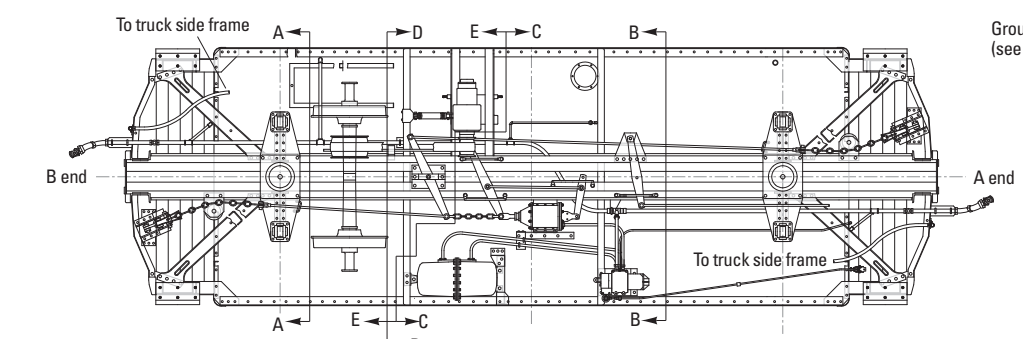
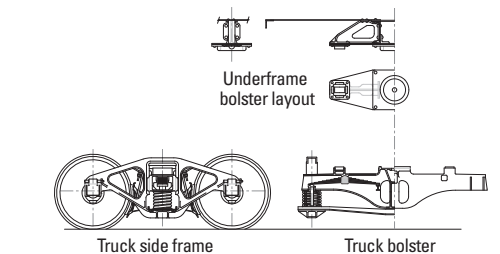

Drawn for *Model Railroader Magazine* by **Harold W. Russell**
 Magazine purchaser may have photocopies of these drawings made as an aid to personal model making but does not have the right to distribute copies of the drawings to others. Contact *Model Railroader* regarding commercial use of these drawings.

Rivet pattern layouts

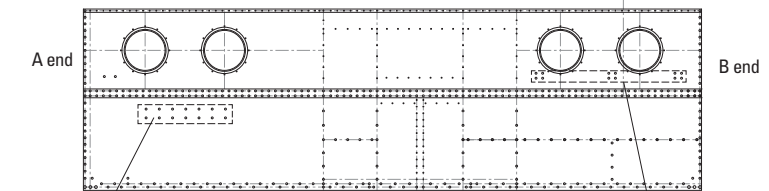

This grouping of 14 rivets located on A end of panel A-B used for table mounting.

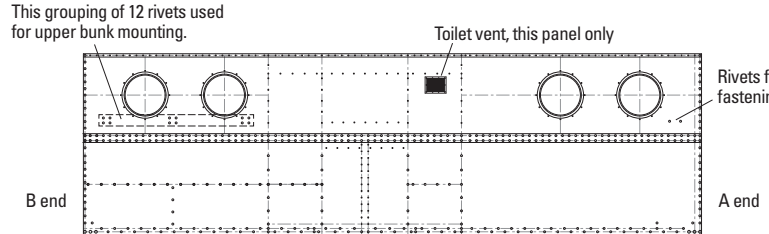

This grouping of 12 rivets used for upper bunk mounting.

Toilet vent, this panel only

Rivets for water tank fastening, this sheet only.

