

1:20.3-scale delivery wagon

by Ted Stinson | Wiscasset, Maine



If you are modeling a railroad in a period prior to 1920, then you will need a supply of horse-drawn vehicles. This is the forth of several to be offered. The delivery wagon was the classic light transport of its day, comparable to the small van of today. The wheels for this vehicle are made from laser-cut ply and basswood. They are assembled according to the instructions that come with the wheels. They should be sealed with clear lacquer and, when dry, painted to suit.

Construction

Begin by assembling the frame. When finished, make the front axle and shafts. When both of these assemblies are done, seal them with clear lacquer and, when dry, paint them a trim color of your choice. When the paint has been allowed to dry for at least 24 hours, fit these two parts together with a pin through the A/B ply plates. Now, make the wheels according to the instructions and paint them as above. When they have been allowed to dry for at least 24 hours, they can be fitted on the axles and permanently fixed in place with small eyelets glued to the ends of the axles (be careful to avoid getting glue on the wheel hubs).

The body

Now make the body. Begin with the frames shown on the plan. Either pine or firm balsa will do. Cut out two backing pieces from 1/32" plywood. Glue these to the inside of each frame. Now make the floor. Cut a piece of 1/8" firm balsa, 2 1/8" x 5 1/8". Bevel the front edge 45 degrees. Fit and glue a piece of pine or bass, 1/16" x 3/8" x 2 1/8" to the front. Sand the bottom edge smooth and flush. Now glue the sides in place. Cut out the print-wood parts from the 1/16" stock (firm balsa will do nicely). Fit and glue the roof frames (F & R) in place. Make the roof from 1/32" plywood, 2 1/16" wide x 5 1/16" long. At this point, seal the body with clear lacquer. When dry, paint the body to suit.

Details

Now the details, such as the seat and tailgate can be made. These should be sealed and painted before gluing them in place. The cloth flap at the rear should be added last. First, seal the cloth with two coats of clear lacquer, then iron the cloth flat. Finally, cut out the flap and attach it to the roof frame with a piece of 1/16" x 1/8" strip and five pins.

The body can now be glued in place on the frame. Any signage can be made at this time. Signs can be made on your computer and printed on cover stock. Cut them out and glue them in place.

Finally, a brake can be fitted to the wagon. Make the handle from flat wire and connect it to the brakes with a chain fixed at the mid point of the brake rod. In operation, the brake rod was actually split in the middle and, when pulled, the brakes would engage the wheels.

This sheet is a supplement to the April 2006 issue of *Garden Railways* magazine. While supplies last, extra copies of these drawings can be had by sending \$1.50 per set (\$2.00 foreign) to: Sidestreet Bannerworks, PO Box 460222, Denver CO 80246 USA. A complete list of available plans can be found at www.sidestreet.info, or send a stamped, self-addressed envelope to the above address.

A complete kit for this project (including wheels) is available from Northeast Narrow Gauge for \$29.95 + \$6 s&h. Wheels are available separately for \$6 per set + \$2.50 shipping per set. Order from Northeast Narrow Gauge, PO Box 191, Wiscasset ME 04578. Web site: www.nemodel.com

© 2006 by *Garden Railways* and Northeast Narrow Gauge. These drawings may be photocopied by individual modelers for their own personal use. Copying for any commercial use or for distribution is prohibited without written consent from the publisher.

end view
FRONT AXLE



top view

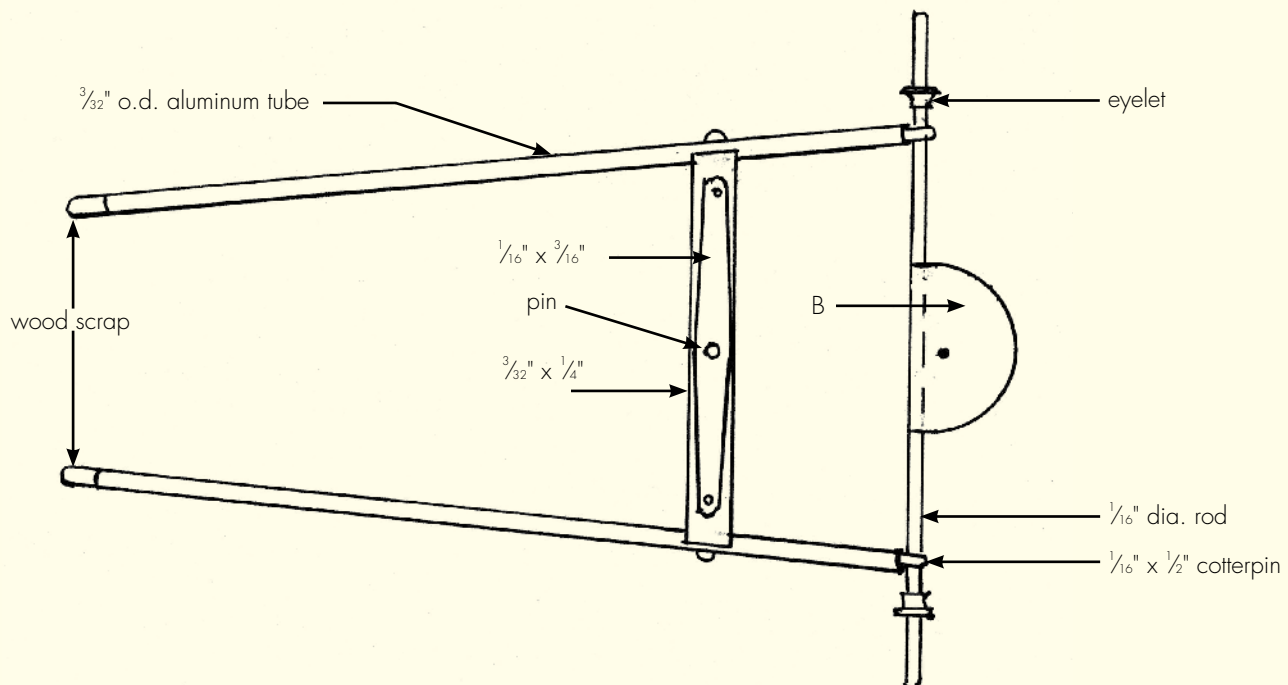

side view
SHAFT

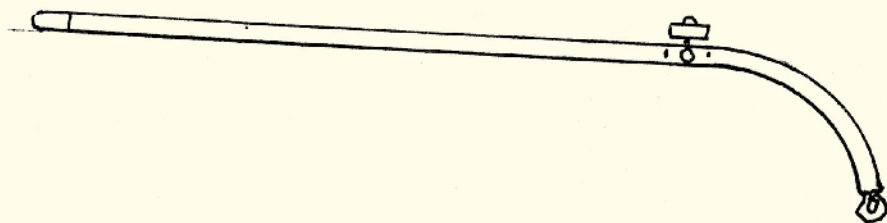

Composite View

side view
FRAME - MAKE 2
(a left and a right)

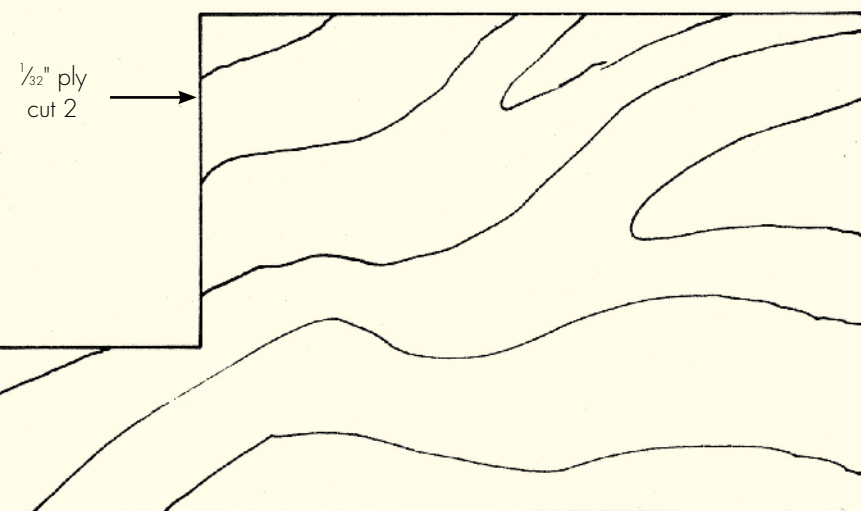
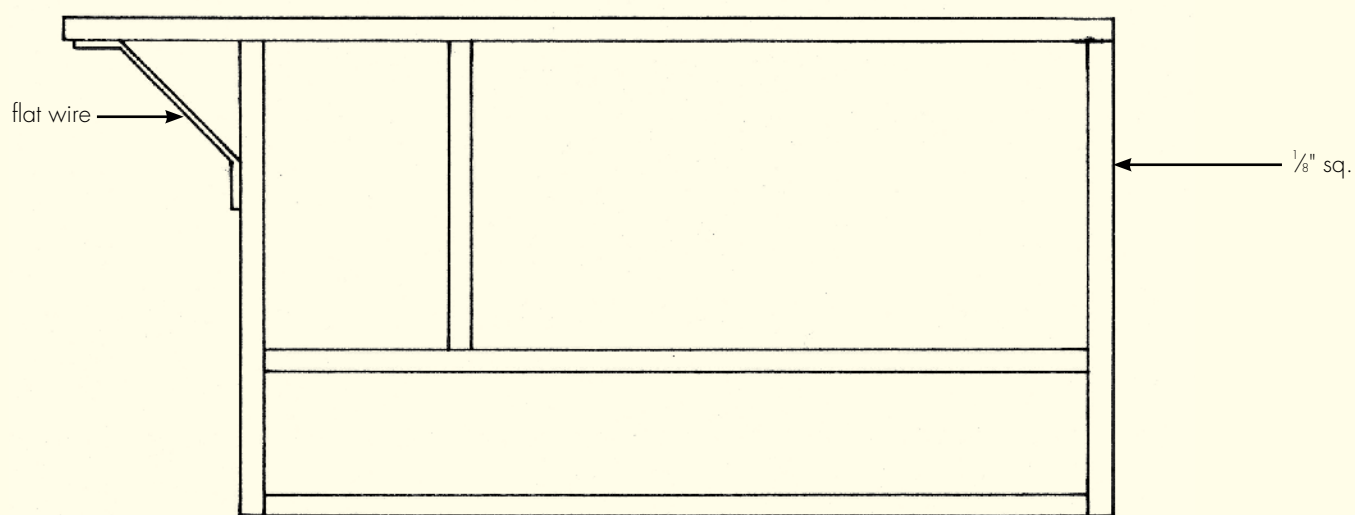

brake handle

MAKE FROM FLAT WIRE

run chain from handle to midpoint of brake rod

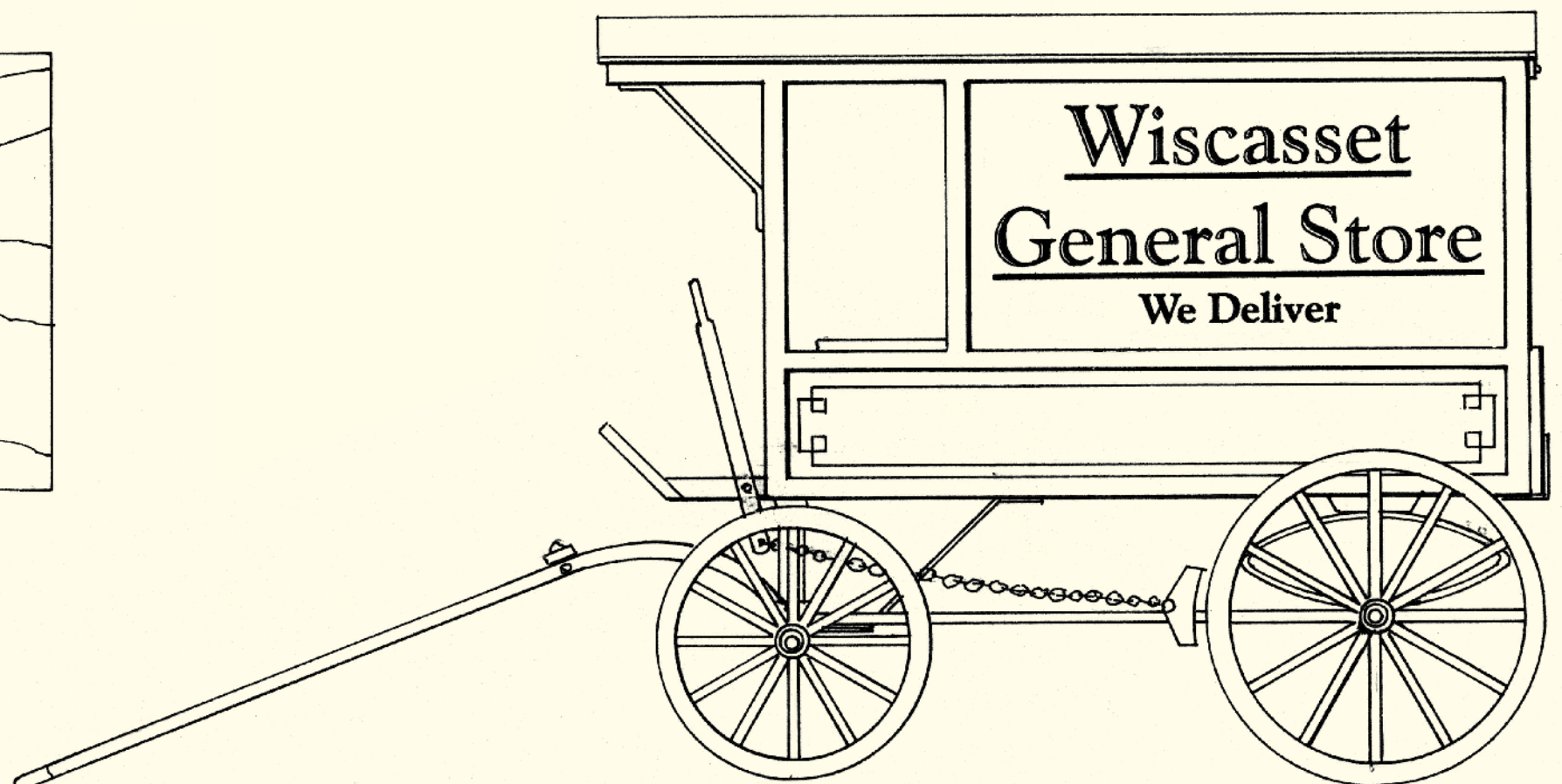
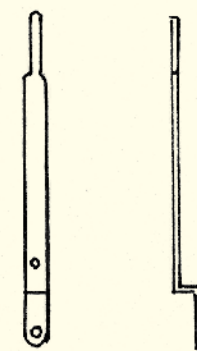

Are you working in a different scale?
 If you are working in 1:32 scale, reduce these drawings to 63%.
 If you are working in 1:29 scale, reduce these drawings to 70%.
 If you are working in 1:24 scale, reduce these drawings to 88%.
 If you are working in 1:22.5 scale, reduce these drawings to 90%.
 If you are working in 16mm scale, enlarge these drawings to 107%.
 If you are working in 1:13.7 (7/8") scale, enlarge these drawings to 148%.

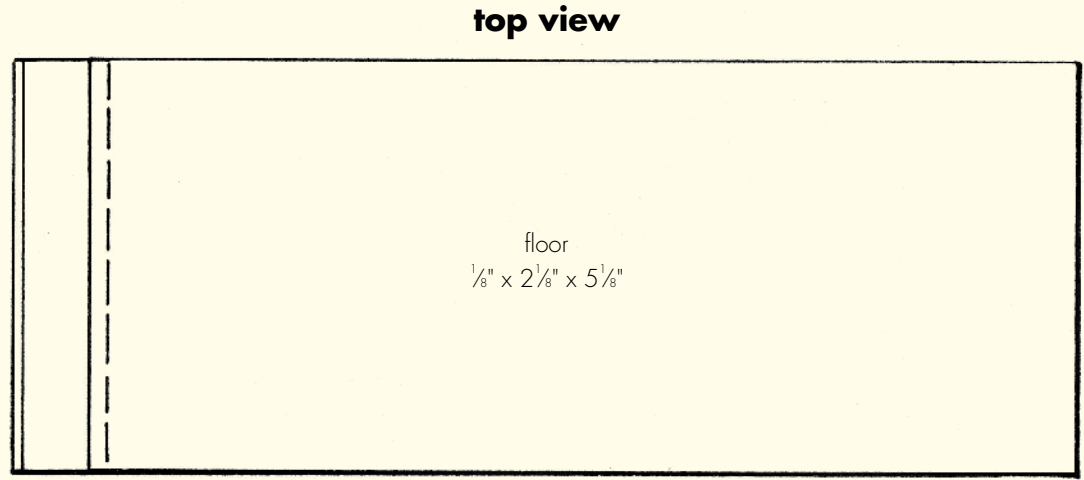
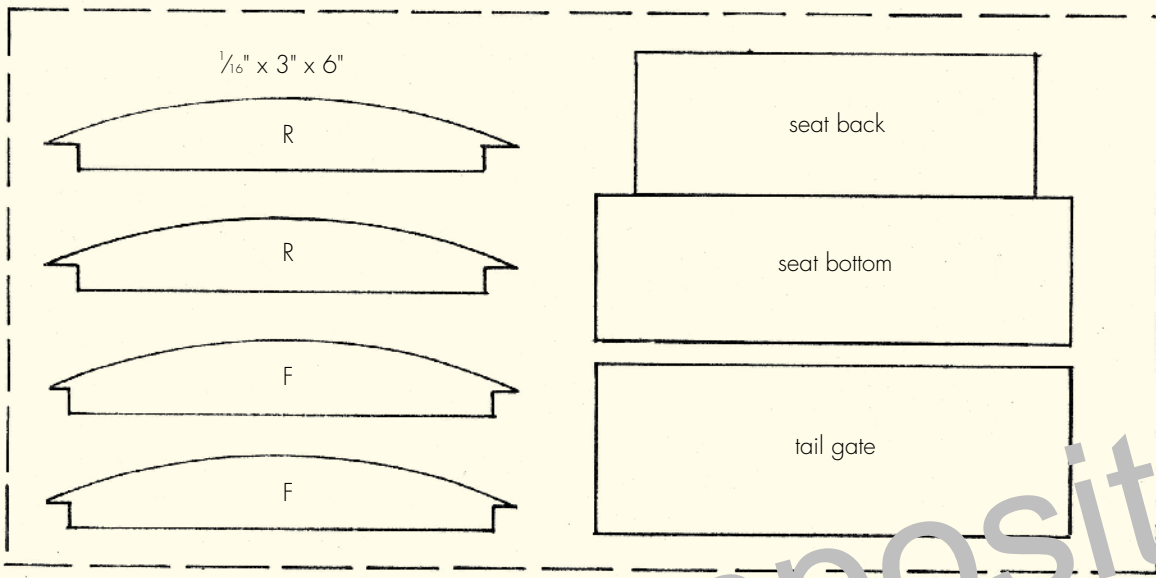
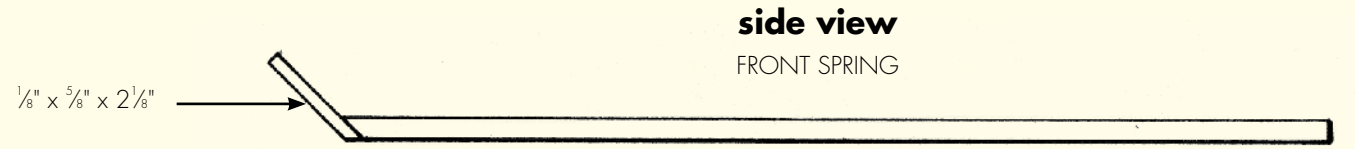
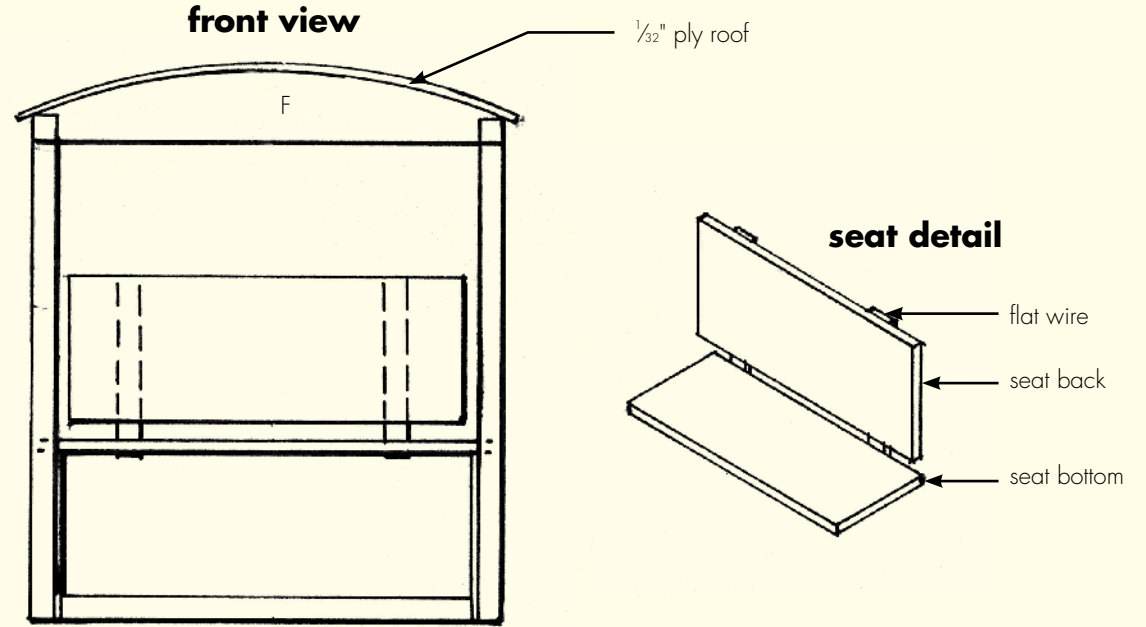
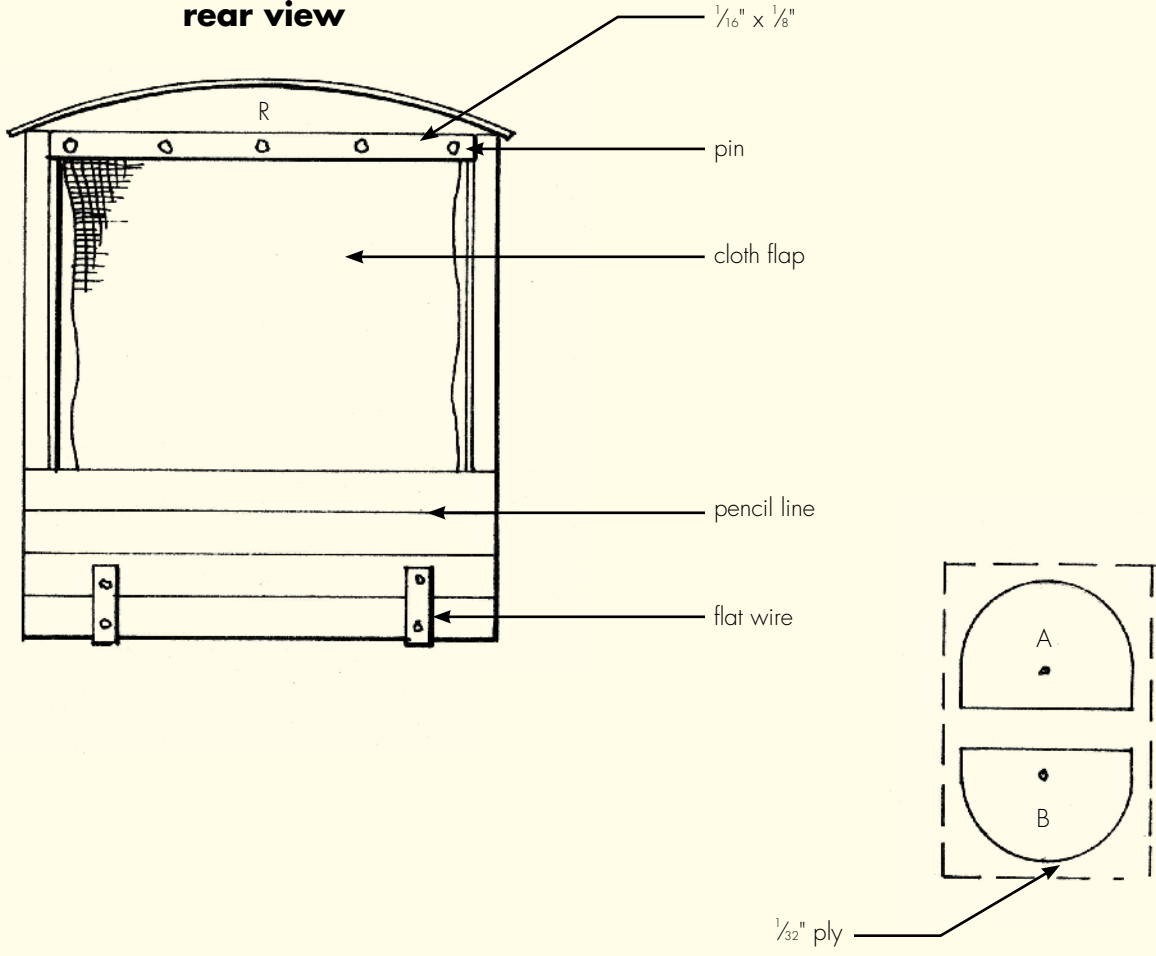

Composite View

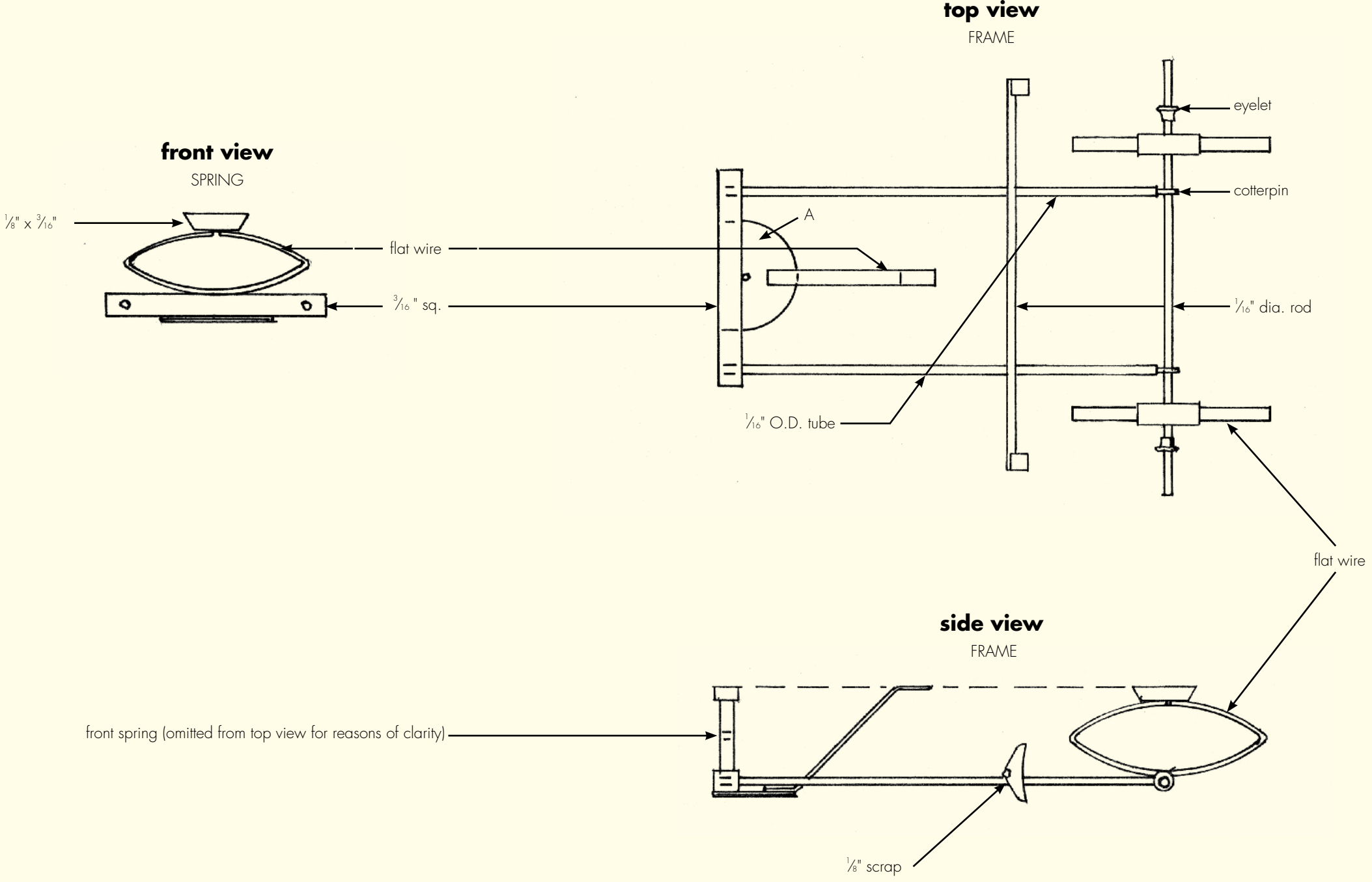

end view

FRONT AXLE



top view

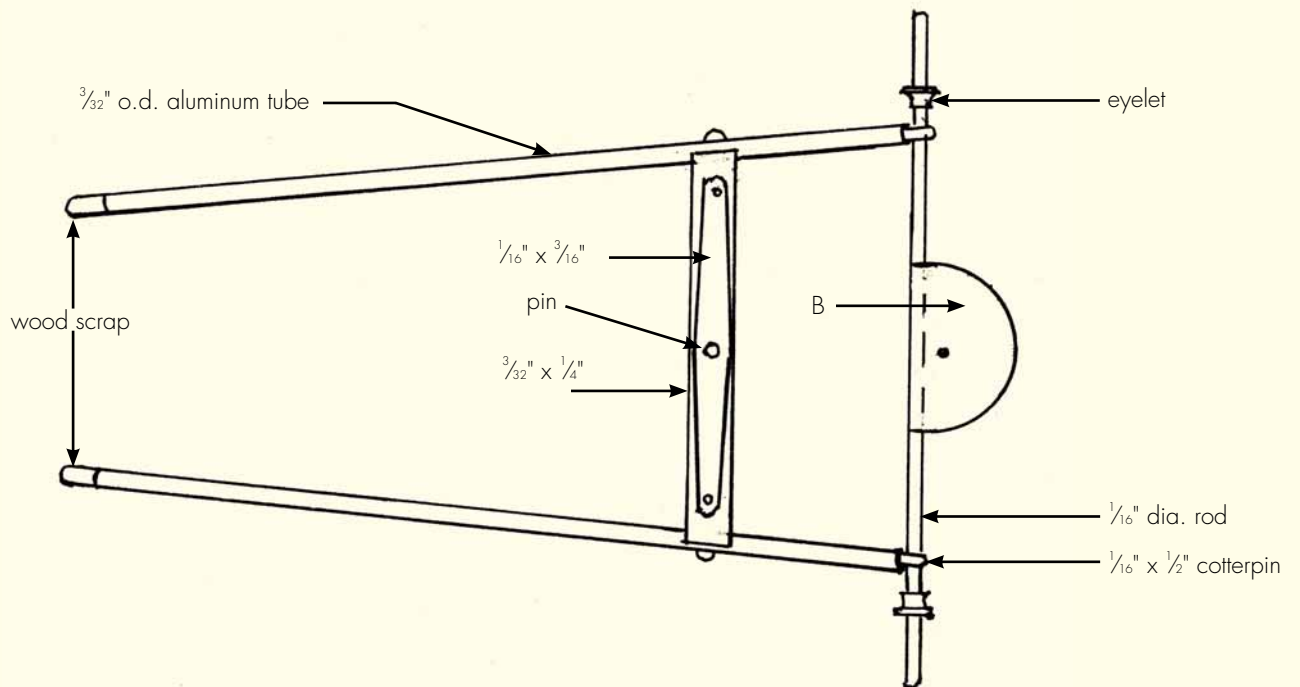

side view

SHAFT

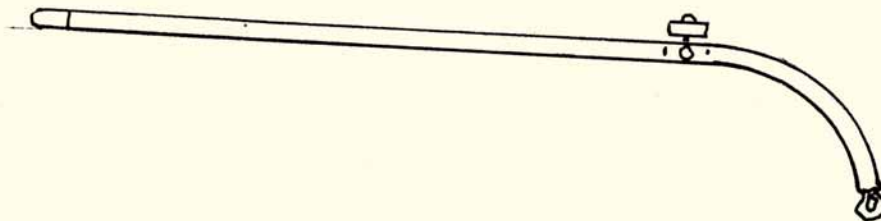

1:20.3-scale delivery wagon

by Ted Stinson | Wiscasset, Maine

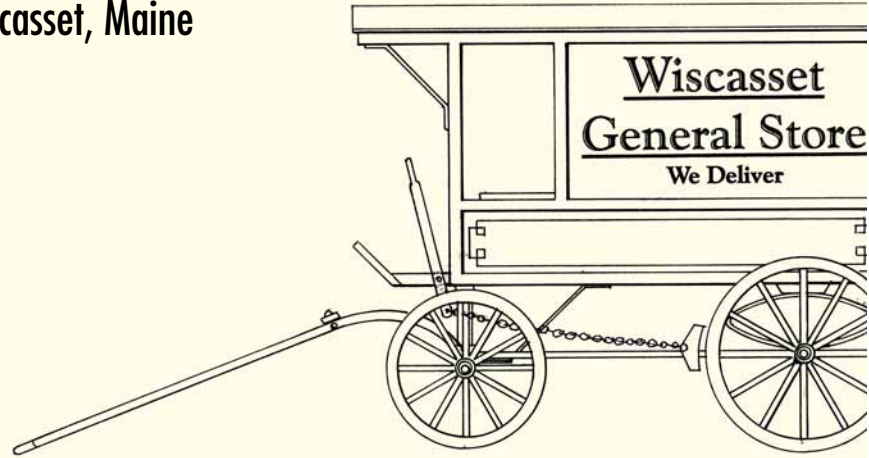

— eyelet

If you are modeling a railroad in a period prior to 1920, then you will need a supply of horse-drawn vehicles. Several to be offered. The delivery wagon was the classic light transport of its day, comparable to the small vans. The wheels for this vehicle are made from laser-cut ply and basswood. They are assembled according to the instructions with the wheels. They should be sealed with clear lacquer and, when dry, painted to suit.

Construction

Begin by assembling the frame. When finished, make the front axle and shafts. When both of these assemblies are finished, seal them with clear lacquer and, when dry, paint them a trim color of your choice. When the paint has been allowed to dry for 24 hours, fit these two parts together with a pin through the A/B ply plates. Now, make the wheels according to the instructions and paint them as above. When they have been allowed to dry for at least 24 hours, they can be fitted on the axle and fixed in place with small eyelets glued to the ends of the axles (be careful to avoid getting glue on the wheel hub).

The body

Now make the body. Begin with the frames shown on the plan. Either pine or firm balsa will do. Cut out two body sides from 1/32" plywood. Glue these to the inside of each frame. Now make the floor. Cut a piece of 1/8" firm balsa, 2 1/8" long, with the front edge 45 degrees. Fit and glue a piece of pine or bass, 1/16" x 5/8" x 2 1/8" to the front. Sand the bottom edge of the floor. Now glue the sides in place. Cut out the print-wood parts from the 1/16" stock (firm balsa will do nicely). Fit the front and rear frames (F & R) in place. Make the roof from 1/32" plywood, 2 9/16" wide x 5 9/16" long. At this point, seal the body with clear lacquer. When dry, paint the body to suit.

Details

Now the details, such as the seat and tailgate can be made. These should be sealed and painted before gluing. The cloth flap at the rear should be added last. First, seal the cloth with two coats of clear lacquer, then iron the cloth flat. Cut out the flap and attach it to the roof frame with a piece of 1/16" x 1/8" strip and five pins.

The body can now be glued in place on the frame. Any signage can be made at this time. Signs can be made from cover stock and printed on. Cut them out and glue them in place.

Finally, a brake can be fitted to the wagon. Make the handle from flat wire and connect it to the brakes with a pin at the mid point of the brake rod. In operation, the brake rod was actually split in the middle and, when pulled, the brake shoes pressed against the wheels.

* * *

This sheet is a supplement to the April 2006 issue of *Garden Railways* magazine. While supplies last, extra copies of this sheet can be had by sending \$1.50 per set (\$2.00 foreign) to: Sidestreet Bannerworks, PO Box 460222, Denver, CO 80222. A complete list of available plans can be found at www.sidestreet.info, or send a stamped, self-addressed envelope to the same address.

A complete kit for this project (including wheels) is available from Northeast Narrow Gauge for \$29.95 + \$4.95 shipping. A set of wheels is available separately for \$6 per set + \$2.50 shipping per set. Order from Northeast Narrow Gauge, PO Box 404578, Denver, CO 80248. Web site: www.nemodel.com

© 2006 by *Garden Railways* and Northeast Narrow Gauge. These drawings may be photocopied by individuals for their own personal use. Copying for any commercial use or for distribution is prohibited without written consent from the publisher.

— 1/16" dia. rod

— 1/16" x 1/2" cotterpin

Plan set #76

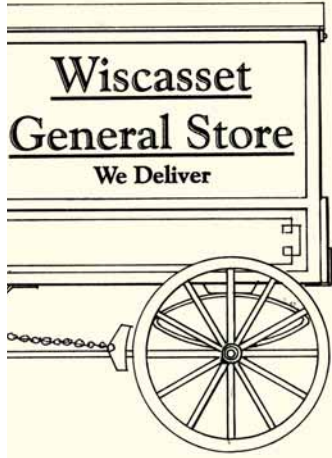

of horse-drawn vehicles. This is the forth of
 , comparable to the small van of today. The
 led according to the instructions that come
 to suit.

on both of these assemblies are done, seal them
 e paint has been allowed to dry for at least 24
 e the wheels according to the instructions and
 ey can be fitted on the axles and permanently
 getting glue on the wheel hubs).

balsa will do. Cut out two backing pieces from
 iece of $\frac{1}{8}$ " firm balsa, $2\frac{1}{8}$ " x $5\frac{1}{8}$ ". Bevel the
 front. Sand the bottom edge smooth and flush.
 :m balsa will do nicely). Fit and glue the roof
 At this point, seal the body with clear lacquer.

l and painted before gluing them in place. The
 ar lacquer, then iron the cloth flat. Finally, cut
 pins.

his time. Signs can be made on your computer

onnect it to the brakes with a chain fixed at the
 lle and, when pulled, the brakes would engage

While supplies last, extra copies of these draw-
 ks, PO Box 460222, Denver CO 80246 USA. A
 amped, self-addressed envelope to the above

arrow Gauge for \$29.95 + \$6 s&h. Wheels are
 st Narrow Gauge, PO Box 191, Wiscasset ME

ie photocopied by individual modelers for their
 without written consent from the publisher.



side view

FRAME - MAKE 2
(a left and a right)

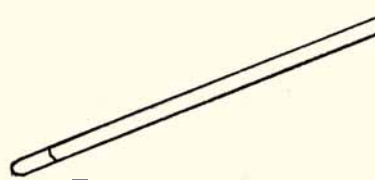
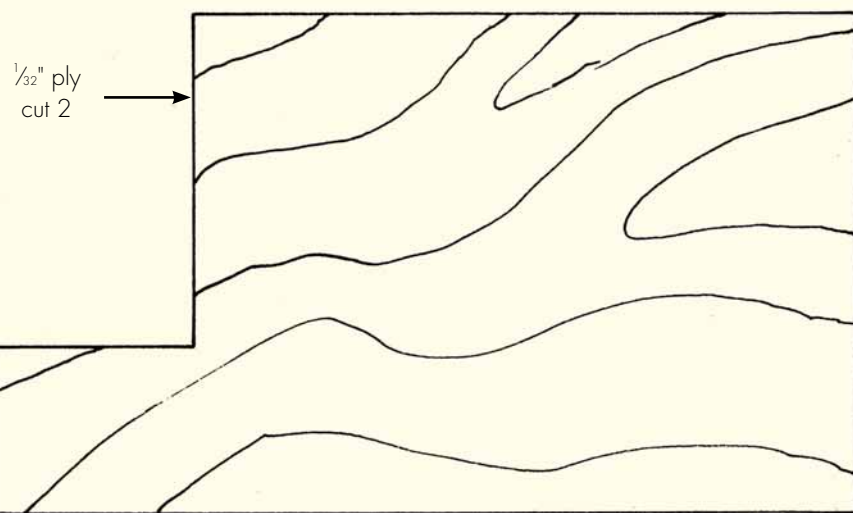
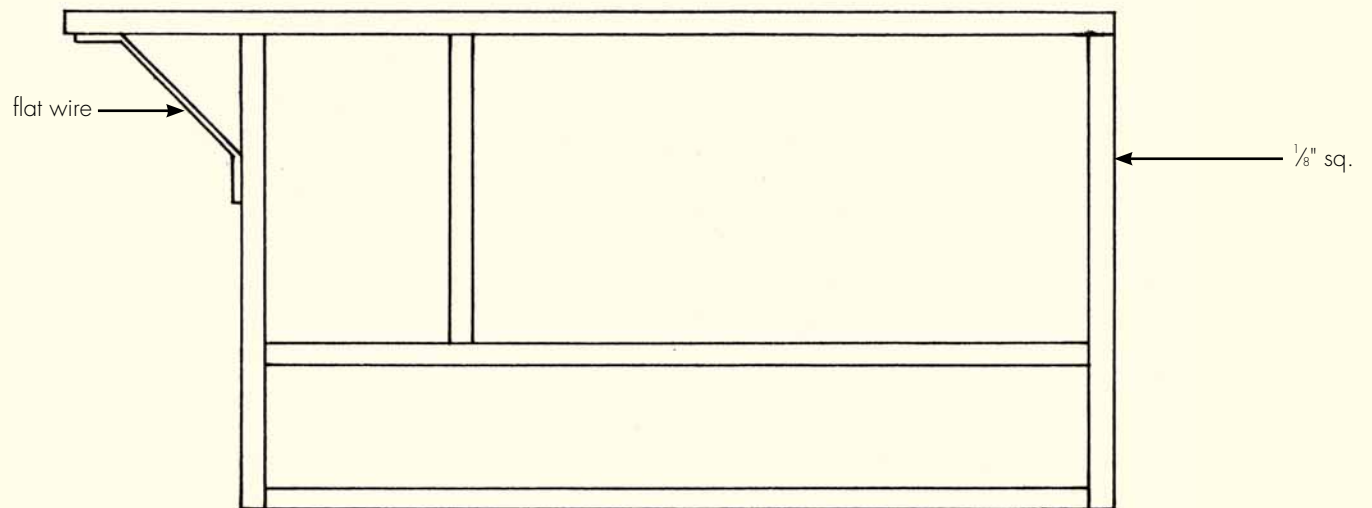

complete list of available plans can be found at www.sidestreet.info, or send a stamped, self-addressed envelope to the address.

A complete kit for this project (including wheels) is available from Northeast Narrow Gauge for \$29.95 + shipping. The wheels are available separately for \$6 per set + \$2.50 shipping per set. Order from Northeast Narrow Gauge, PO Box 04578. Web site: www.nemodel.com

© 2006 by Garden Railways and Northeast Narrow Gauge. These drawings may be photocopied by individuals for their own personal use. Copying for any commercial use or for distribution is prohibited without written consent from the publisher.

1/8" sq.

brake handle

MAKE FROM FLAT WIRE

run chain from handle to midpoint of brake rod

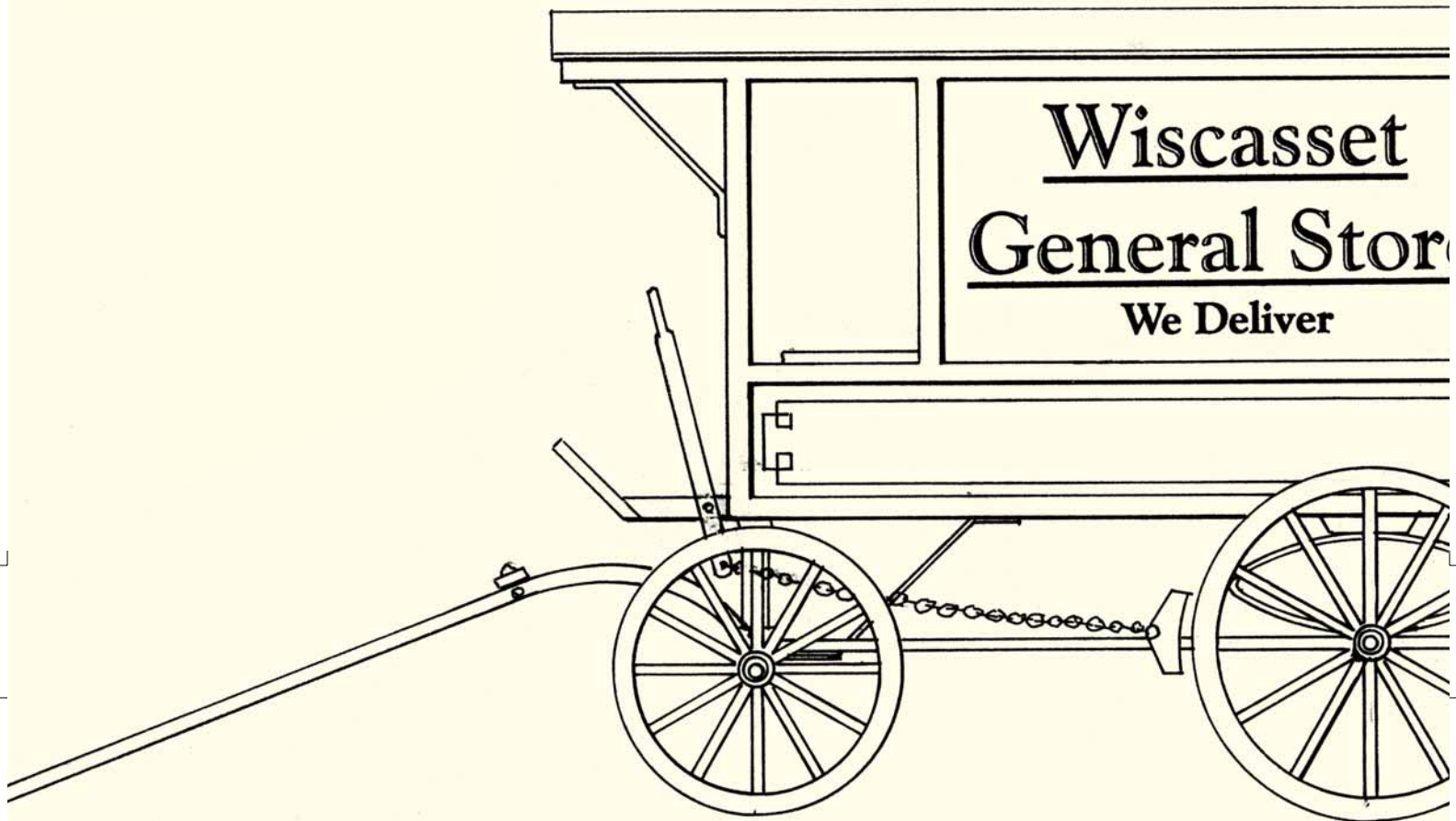
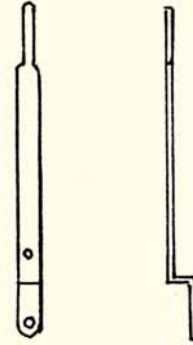

amped, self-addressed envelope to the above

arrow Gauge for \$29.95 + \$6 s&h. Wheels are
st Narrow Gauge, PO Box 191, Wiscasset ME

re photocopied by individual modelers for their
without written consent from the publisher.

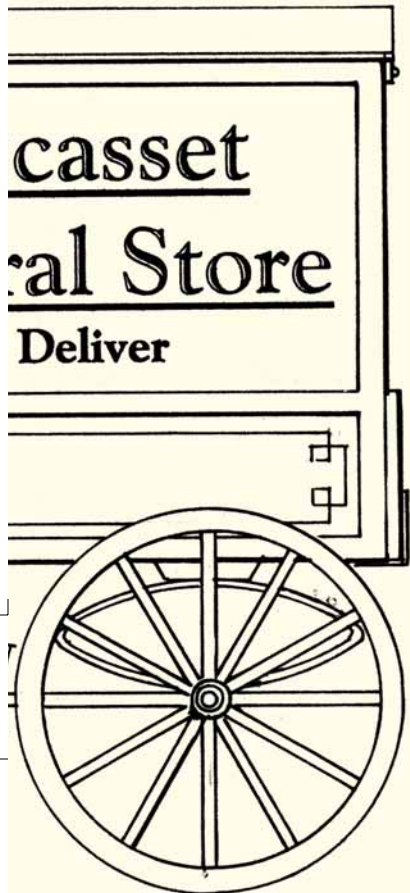

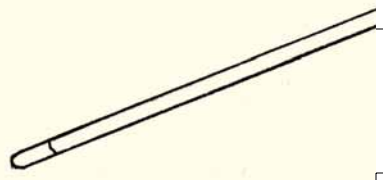

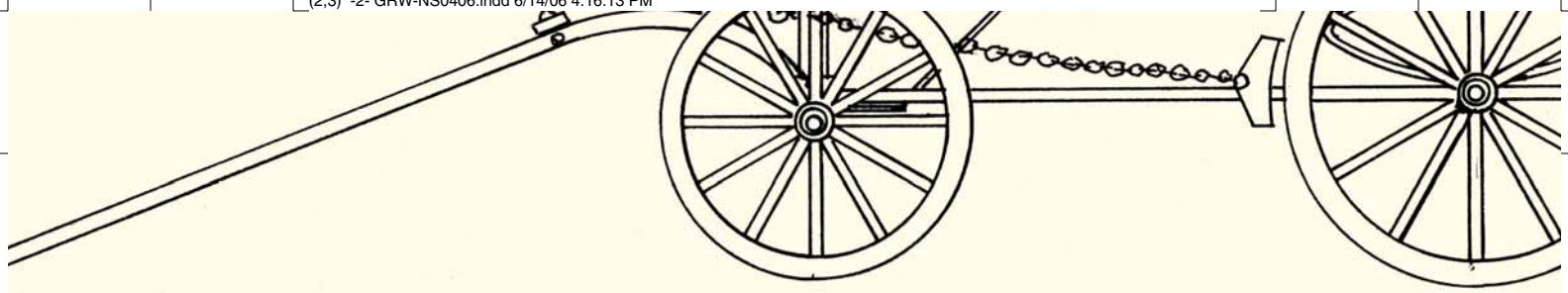

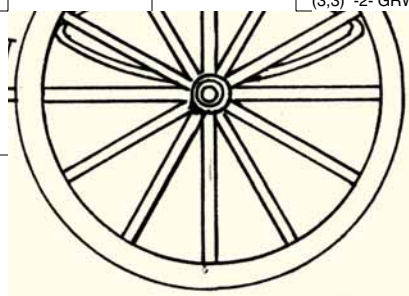

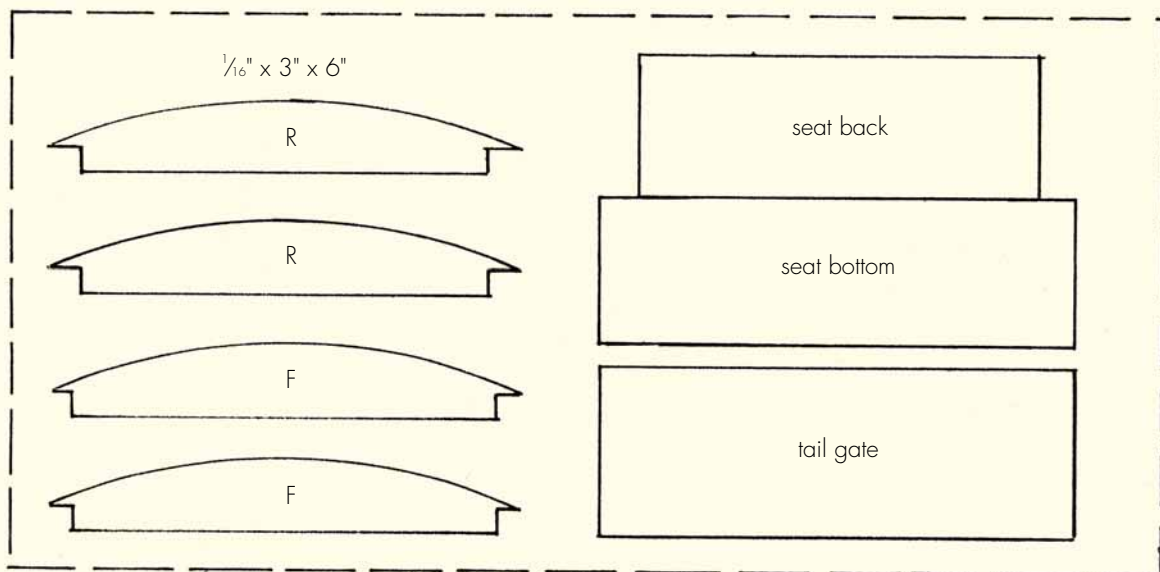
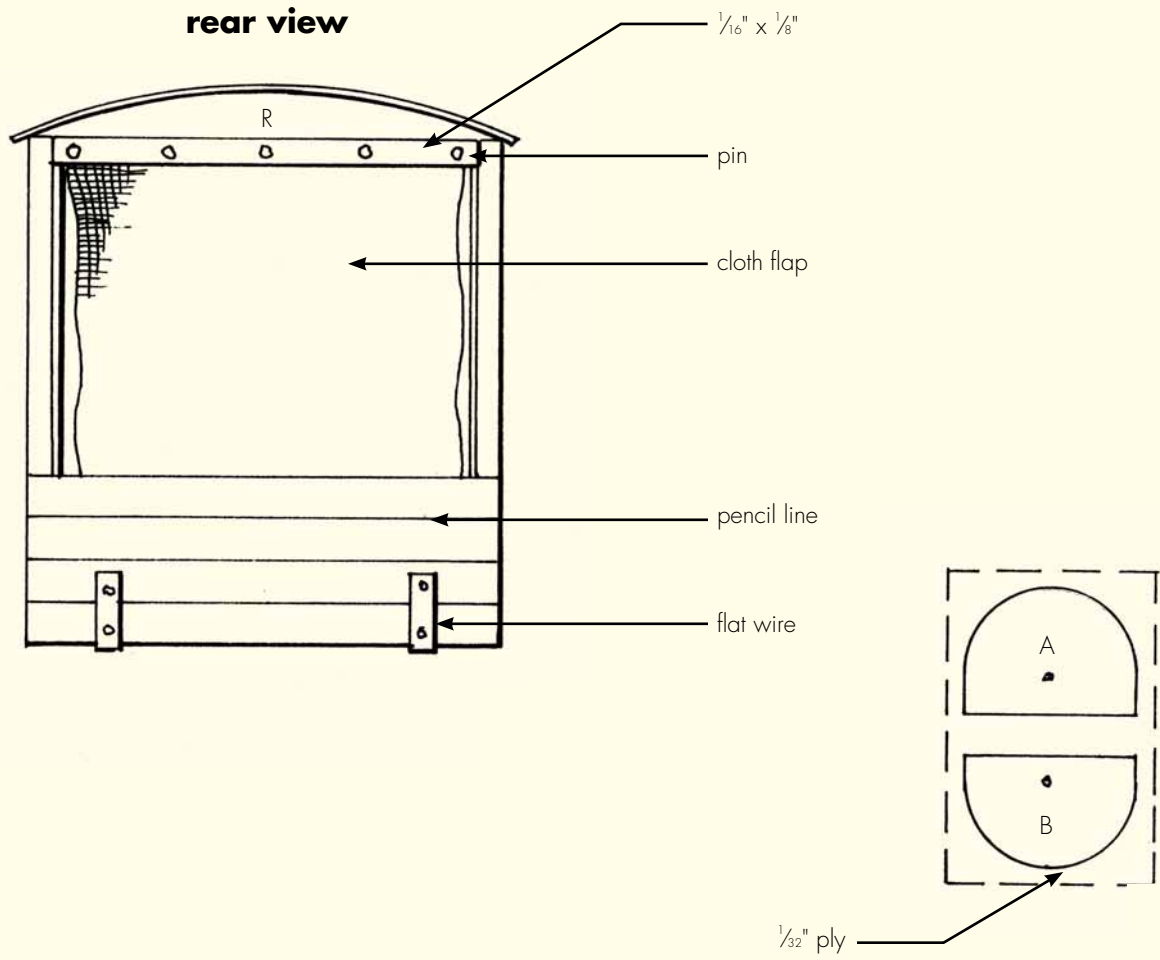

Are you working in a different scale?

If you are working in 1:32 scale, reduce these drawings to 63%

If you are working in 1:29 scale, reduce these drawings to 70%

If you are working in 1:24 scale, reduce these drawings to 88%

If you are working in 1:22.5 scale, reduce these drawings to 90%

If you are working in 16mm scale, enlarge these drawings to 100%

If you are working in 1:13.7 (7/8") scale, enlarge these drawing

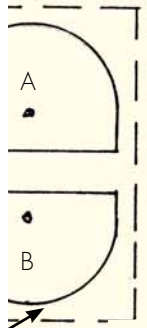

front view

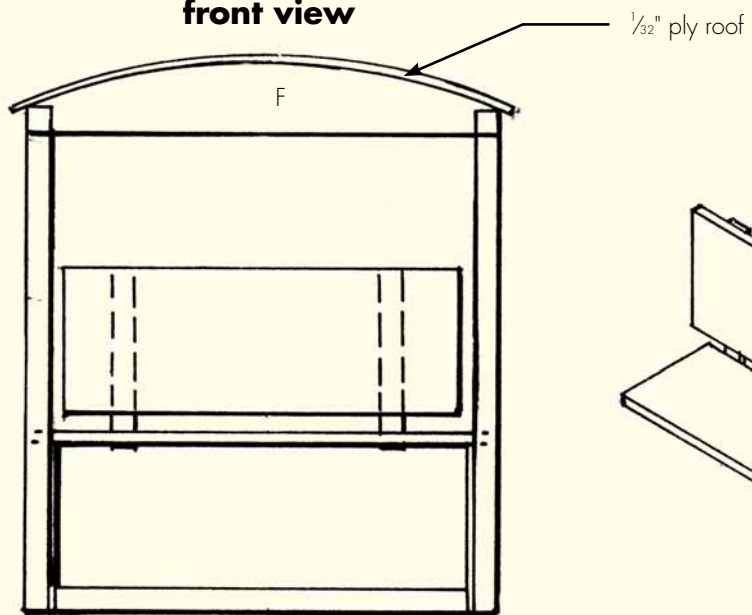

seat detail

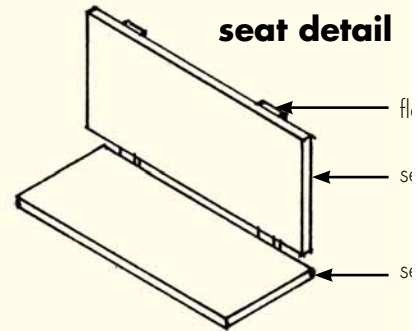

side view

FRONT SPRING

$\frac{1}{8}'' \times \frac{5}{8}'' \times 2\frac{1}{8}''$

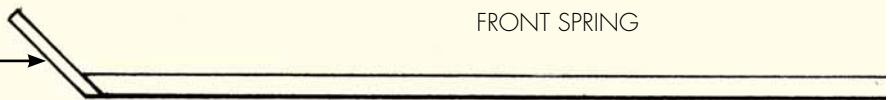

top view

floor
 $\frac{1}{8}'' \times 2\frac{1}{8}'' \times 5\frac{1}{8}''$

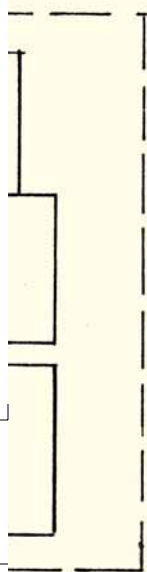
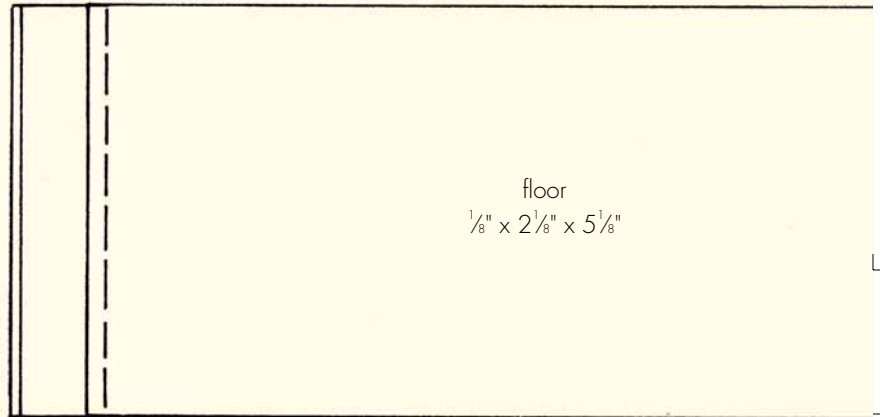

Print scale?

- reduce these drawings to 63%.
- reduce these drawings to 70%.
- reduce these drawings to 88%.
- reduce these drawings to 90%.
- enlarge these drawings to 107%.
- scale, enlarge these drawings to 148%.

of

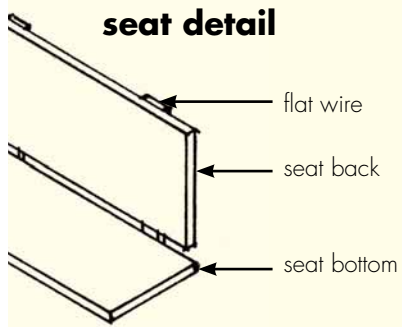

W
NG

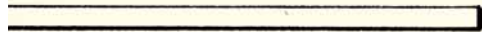

W

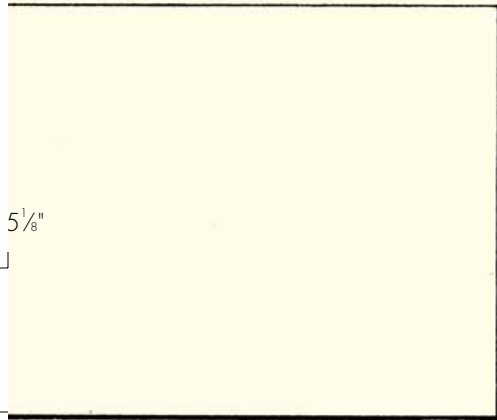

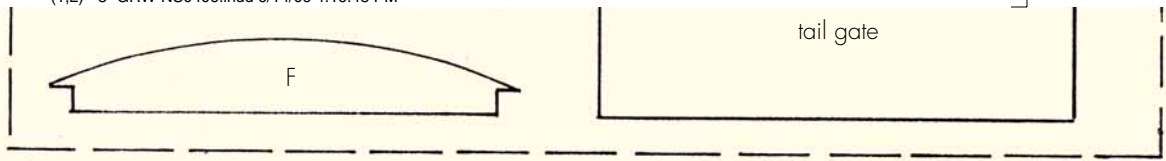

front view

SPRING

$\frac{1}{8}'' \times \frac{3}{16}''$

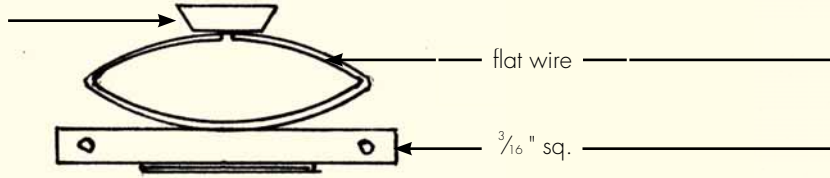

flat wire

$\frac{3}{16}''$ sq.

front spring (omitted from top view for reasons of clarity)

top view

FRAME

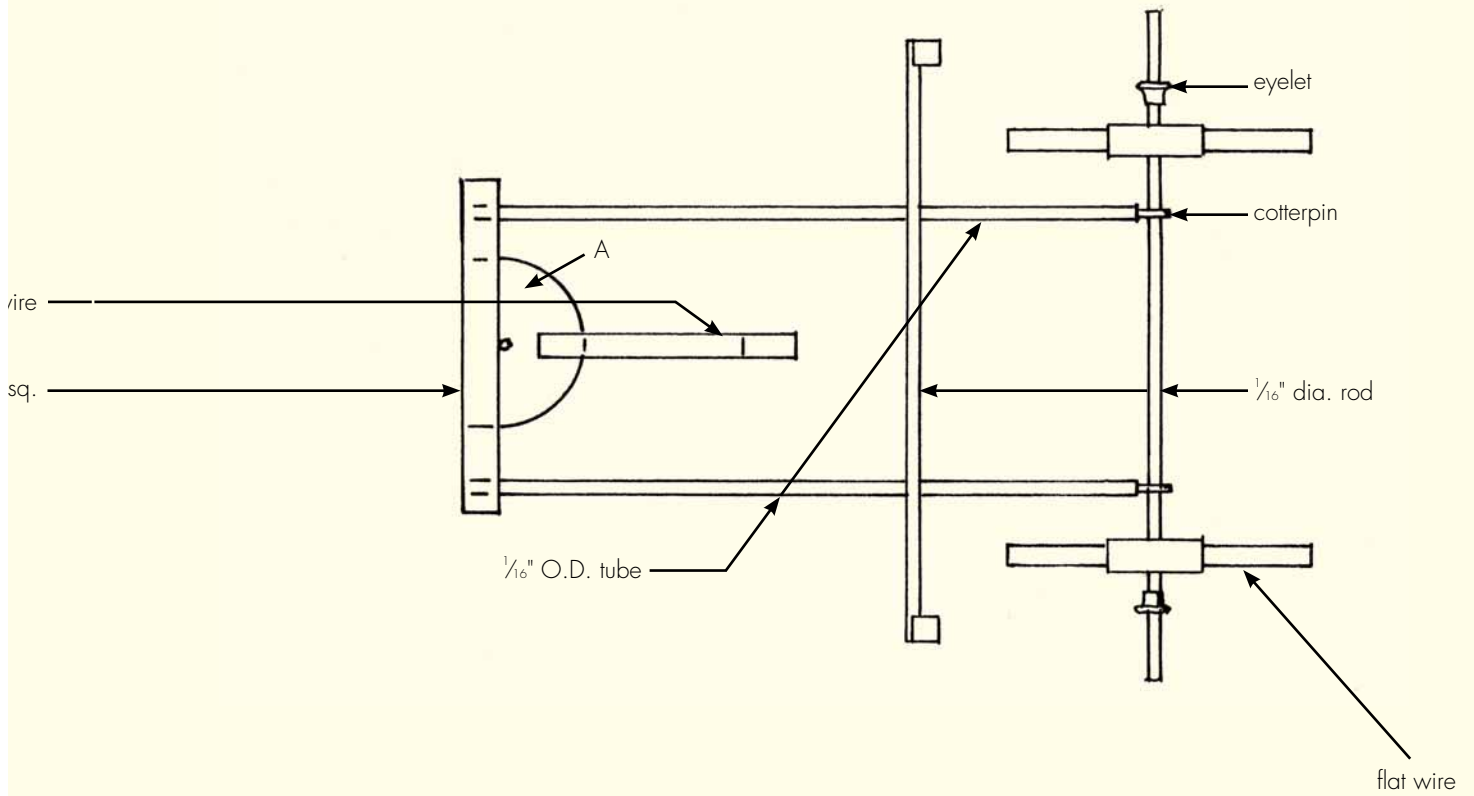

side view

FRAME

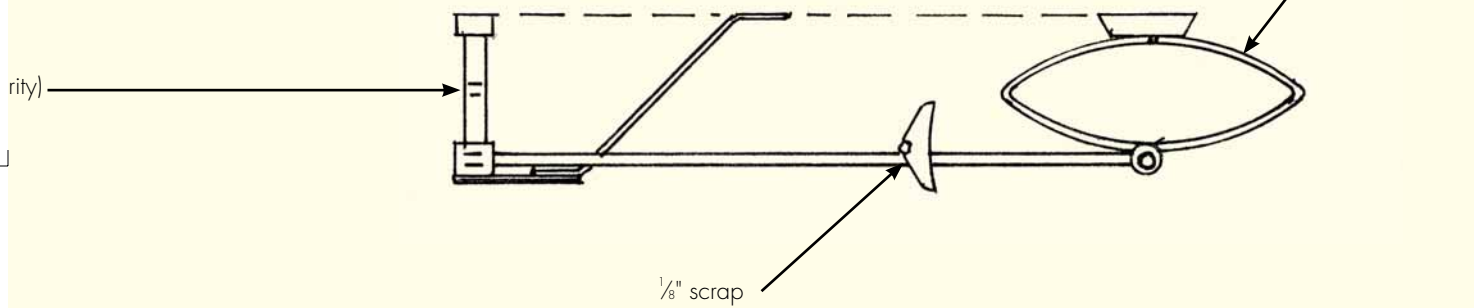

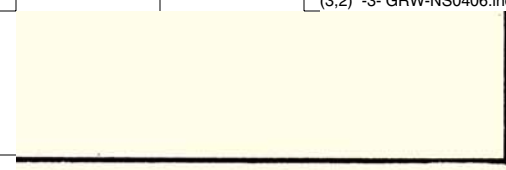

let
erpin

dia. rod

flat wire

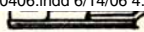

$\frac{1}{8}$ " scrap

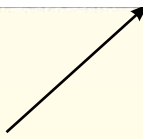

©2006 Northeast Narrow Gauge