

# 1:20.3-scale lobster boat (waterline model), part 1: basic boat

by Ted Stinson | Wiscasset, Maine

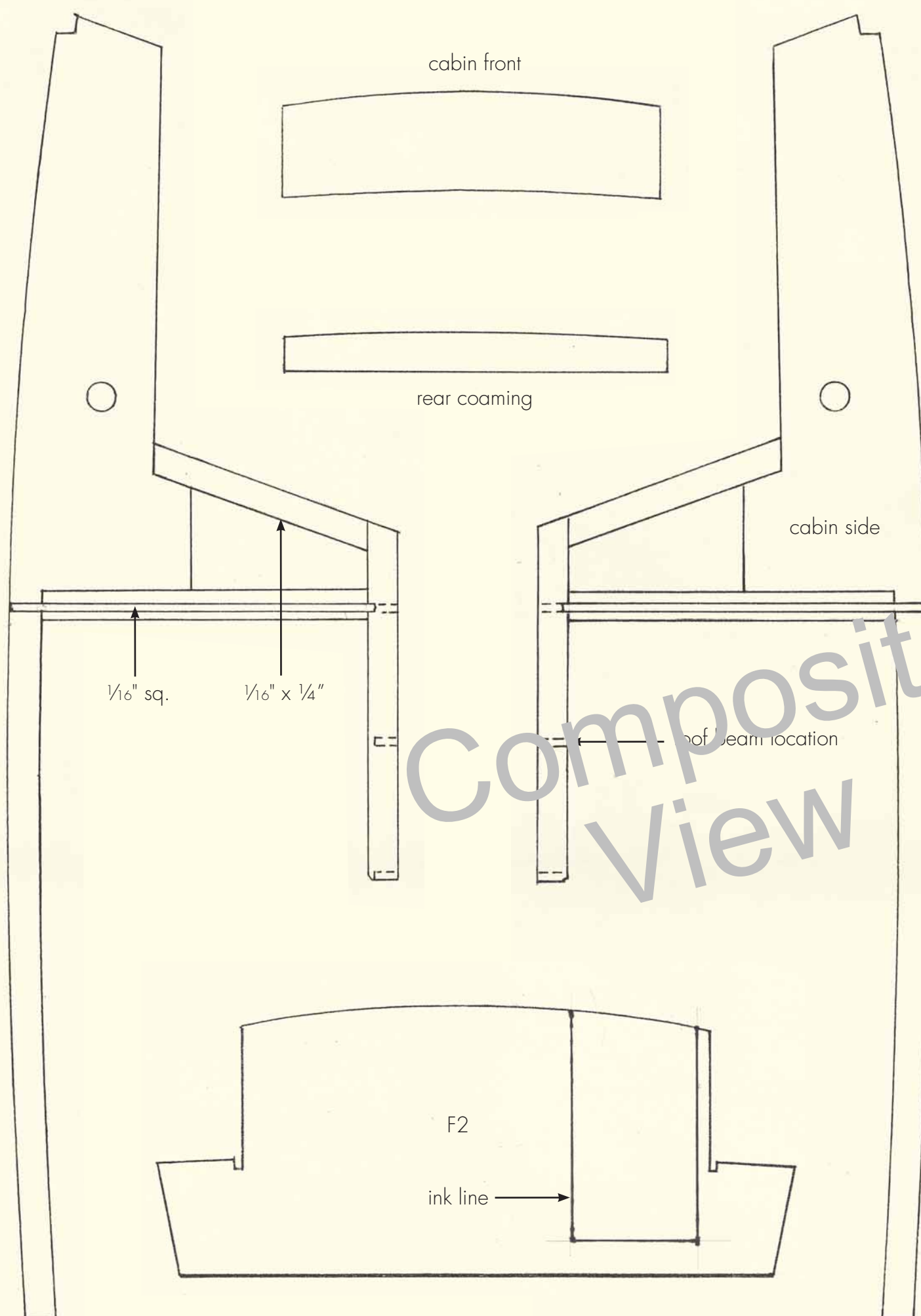
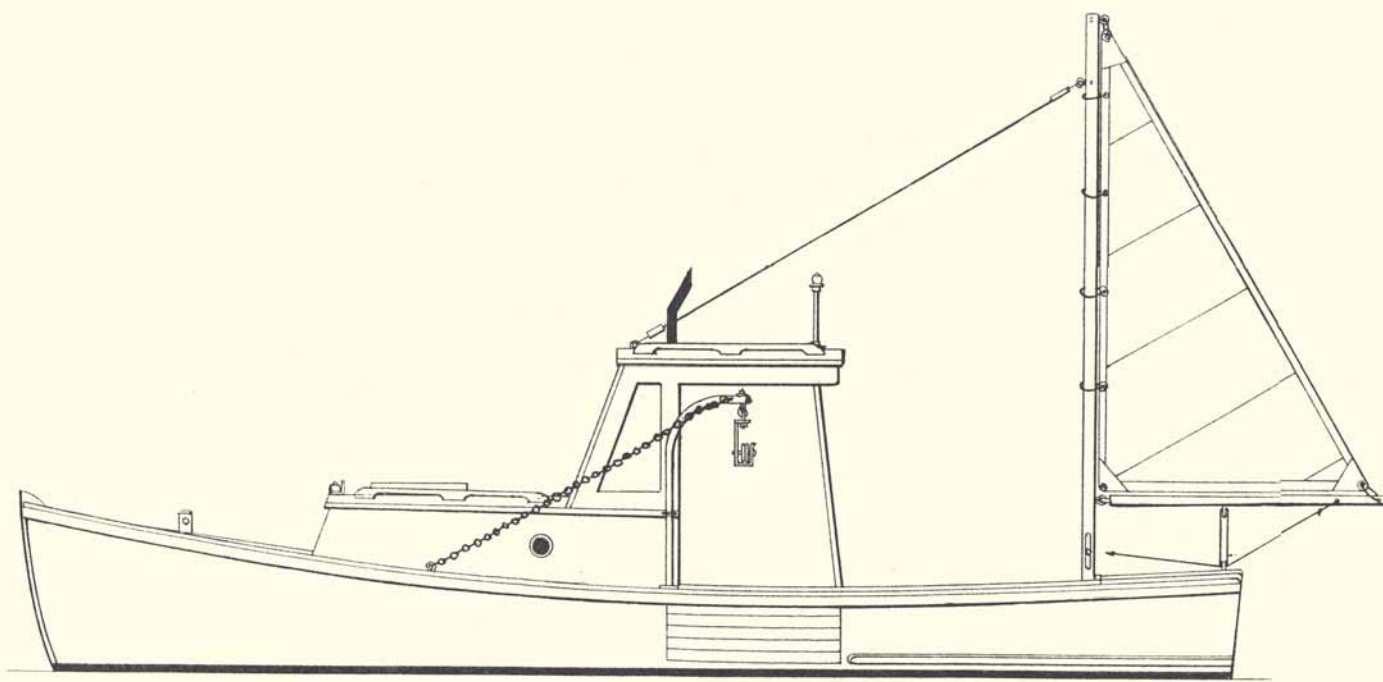

Lobstering became a profitable industry in the 20th century, served by boats that evolved along with the industry. Before WWI and the availability of internal-combustion engines, lobsters were not considered a great delicacy and the industry was carried on from sailing sloops, such as the Friendship sloop. After WWI came cars, roads, and tourists, and lobsters became a valuable catch. Small, wooden boats with modified automobile engines became the standard vessel to serve the industry. This is such a lobster boat.

In the 1960s, two things happened that greatly influenced the industry. Fiberglass boats and the interstate highway system led to bigger markets, bigger boats, and bigger catches. Those excesses led to the present over-fished conditions.

Finding an example of an earlier, wooden boat for these plans was not easy. As it turned out, I found two, not in the water, of course, but still maintained with some care. Also, I decided that a waterline model made the most sense. I wanted a model that was next to a dock—possibly unloading its catch. I did not want to leave a model boat floating in a pond, exposed to rain and UV radiation. Maintenance of a full-size wooden boat is bad enough; maintenance of a model would be far worse. A simple, submerged support, such as a couple of bricks, will give you something to set the model on. Also, it is much easier to build a waterline model.

This will be a three-part series. This first part will let you build the basic boat, the second will show you how to detail it, and third will let you build a dock with a lobstering shack.

## Construction

Refer to the plan. From a piece of  $\frac{1}{8}$ " x 5" x 15" plywood, cut the base. Mark the location of F1 & F2. Using  $\frac{1}{32}$ " thick,  $\frac{3}{16}$ "-spaced scribed wood, surface the cockpit area shown on the plan. Use contact cement (such as used in gluing Formica to a shelf) for this. Stain this deck to your liking (we used Golden Oak) and apply two coats of clear lacquer to the deck. Now, using  $\frac{1}{8}$ "-thick balsa, cut out the Stem, F1, F2, F3, and the Transom. Before gluing F2, F3, and the Transom in place, give them a couple of coats of clear lacquer, followed by flat white, water-base acrylic. Mark the ink-line door on F2 at this time. Now glue these items to the base.

Make up the motor box, which is a  $\frac{3}{4}$ " x  $\frac{1}{4}$ " x  $\frac{1}{2}$ " block, paint it white, and glue it in place. Now cut out two deck halves from  $\frac{3}{32}$ "-thick balsa. Glue these together along the centerline. Fit and glue the deck in place on the Frame heads. Finally, add the  $\frac{1}{8}$ " x  $\frac{1}{4}$ " strips. These will need to be painted white prior to gluing them in place. Now, sand the edges of the hull fair in preparation for planking.

Use  $\frac{1}{32}$ " plywood for planking. It is tough and waterproof. First, make a planking pattern using file-folder stock. Cut the plywood slightly oversize. When fitting the planking in place, try to get the edge of the planking flush with the top of the deck (sheer). You will find it much easier to remove excess plywood from the bottom rather than the deck surface. Remove any excess planking from the hull. Now glue a  $\frac{1}{16}$ " x  $\frac{1}{8}$ " strip at the bow (the gripe). Sand this smooth and fair with the hull.

Now cut out the Cabin parts from firm,  $\frac{1}{16}$ " balsa. Protect the plan with wax paper. Make up the cabin sides and the windshield. Fit and glue the cabin sides in place first, followed by the cabin front and the rear coaming. The cabin roof should now be cut and fitted in place. Use file-folder material to make a pattern, then cut the roof from  $\frac{1}{16}$ " x 4" balsa. Once the roof is done, fit and glue the windshield in place, followed by the roof beams. Make up the shelter roof but don't glue it in place yet.

Fill any irregularities in the deck with spackle and sand smooth with 220-grit sandpaper. Using basswood or pine, fit and glue the  $\frac{1}{16}$ "-square toerail in place, followed by the  $\frac{1}{16}$ " x  $\frac{1}{8}$ " rub rail and the  $\frac{1}{8}$ "-square spray rail. Now give any wood not already finished, two coats of clear lacquer. This should be followed by two brush coats of flat-white acrylic (the hull was white).

When dry, fit and glue the shelter roof in place and give it a similar finish treatment. At this point the deck should be brush-painted a color of your choice. Buff or light gray would be typical. The whole model can now be given a light dusting of clear lacquer to seal it and protect it from fingerprints, etc.

At this point the model is ready for detailing, which will be covered in the next installment.

\*\*\*

This sheet is a supplement to the June 2006 issue of *Garden Railways* magazine. While supplies last, extra copies of these drawings can be had by sending \$1.50 per set (\$2.00 foreign) to: Sidestreet Bannerworks, PO Box 460222, Denver CO 80246 USA. A complete list of available plans can be found at [www.sidestreet.info](http://www.sidestreet.info), or send a stamped, self-addressed envelope to the above address.

A complete kit for this project (including appropriate details) is available from Northeast Narrow Gauge for \$50 + \$8 s&h. Order from Northeast Narrow Gauge, PO Box 191, Wiscasset ME 04578. Web site: [www.nemodel.com](http://www.nemodel.com)

© 2006 by Garden Railways and Northeast Narrow Gauge. These drawings may be photocopied by individual modelers for their own personal use. Copying for any commercial use or for distribution is prohibited without written consent from the publisher.

## Are you working in a different scale?

If you are working in 1:32 scale, reduce these drawings to 63%.  
If you are working in 1:29 scale, reduce these drawings to 70%.  
If you are working in 1:24 scale, reduce these drawings to 88%.  
If you are working in 1:22.5 scale, reduce these drawings to 90%.  
If you are working in 16mm scale, enlarge these drawings to 107%.  
If you are working in 1:13.7 ( $\frac{7}{8}$ " scale), enlarge these drawings to 148%.

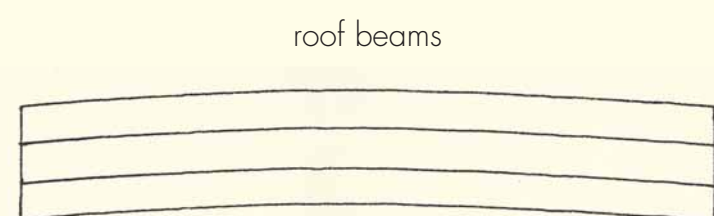

roof beams

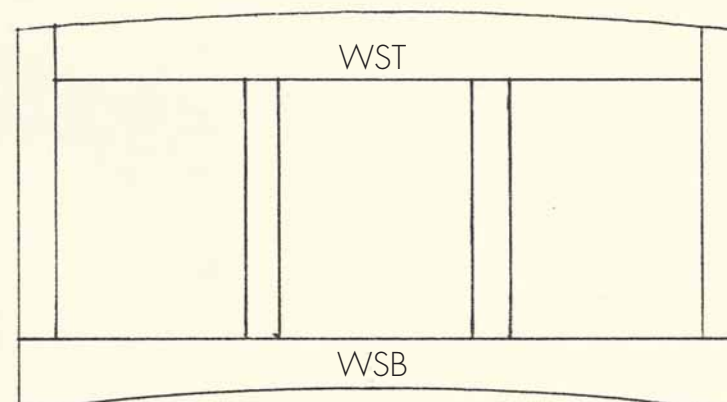

windshield

WST

WSB

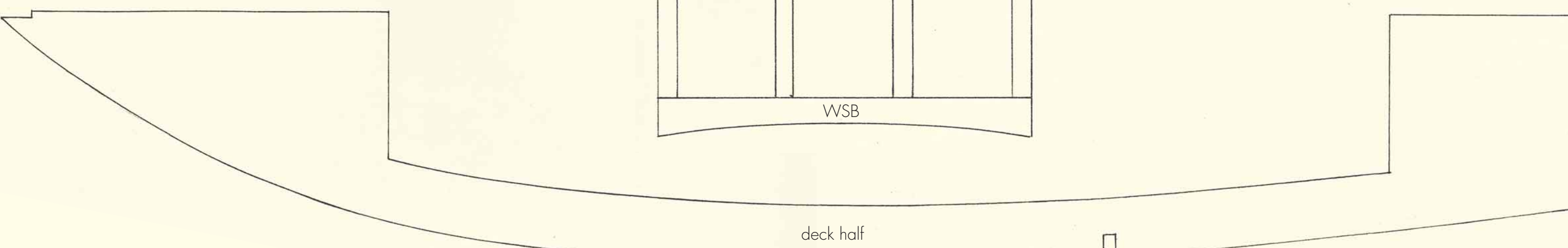

deck half

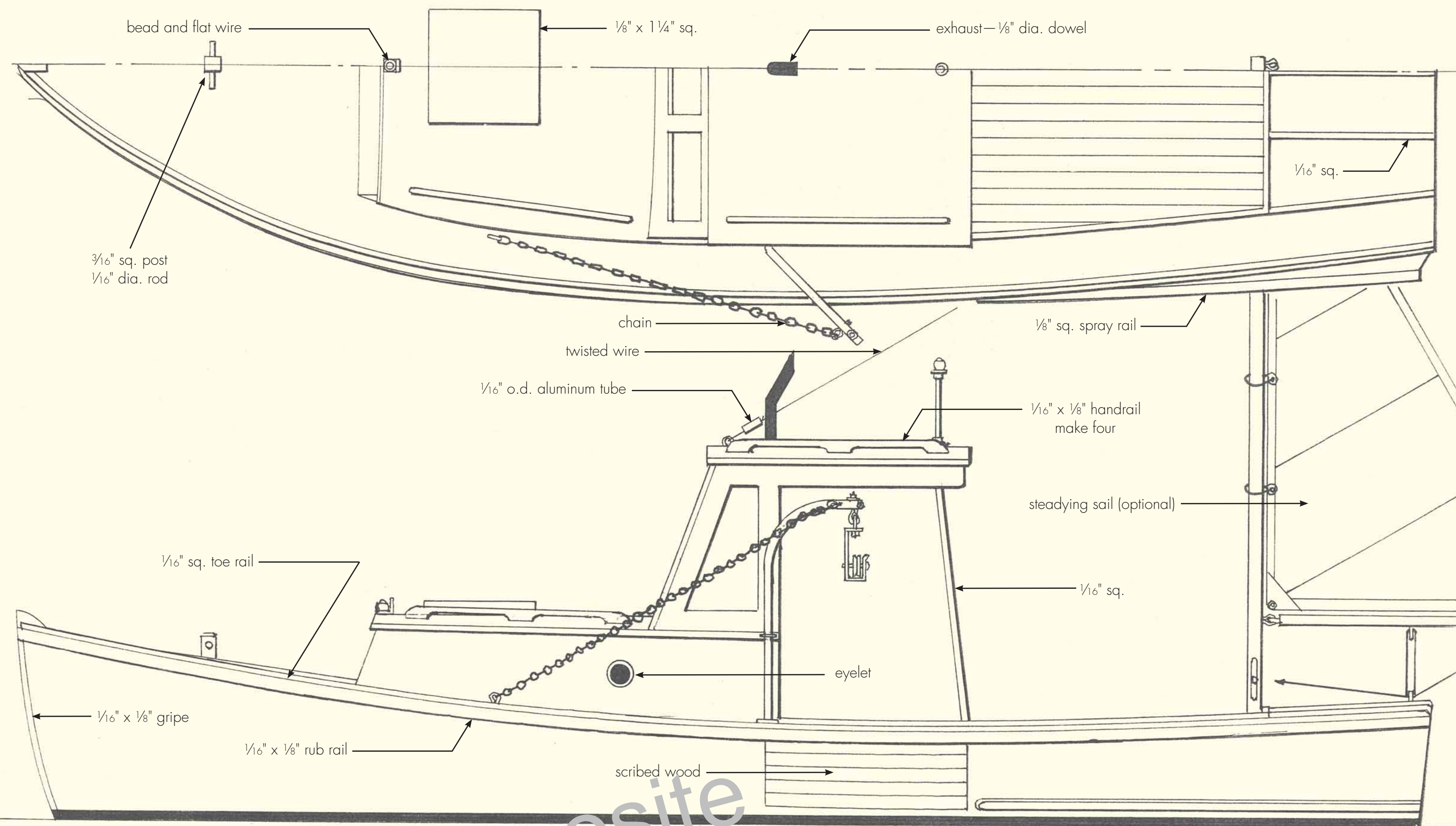

Composite View

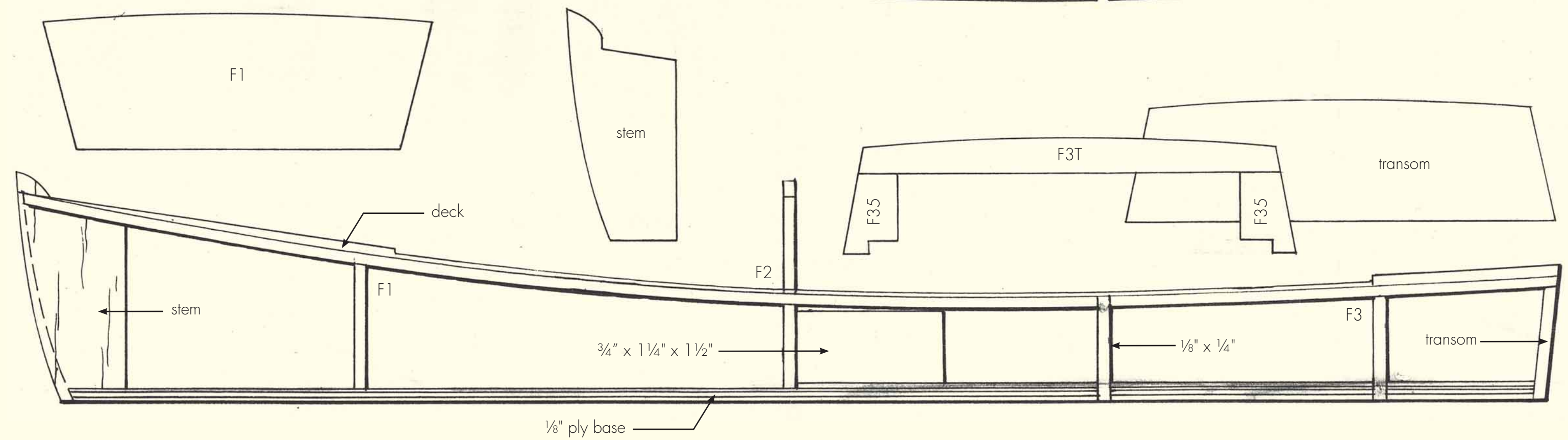
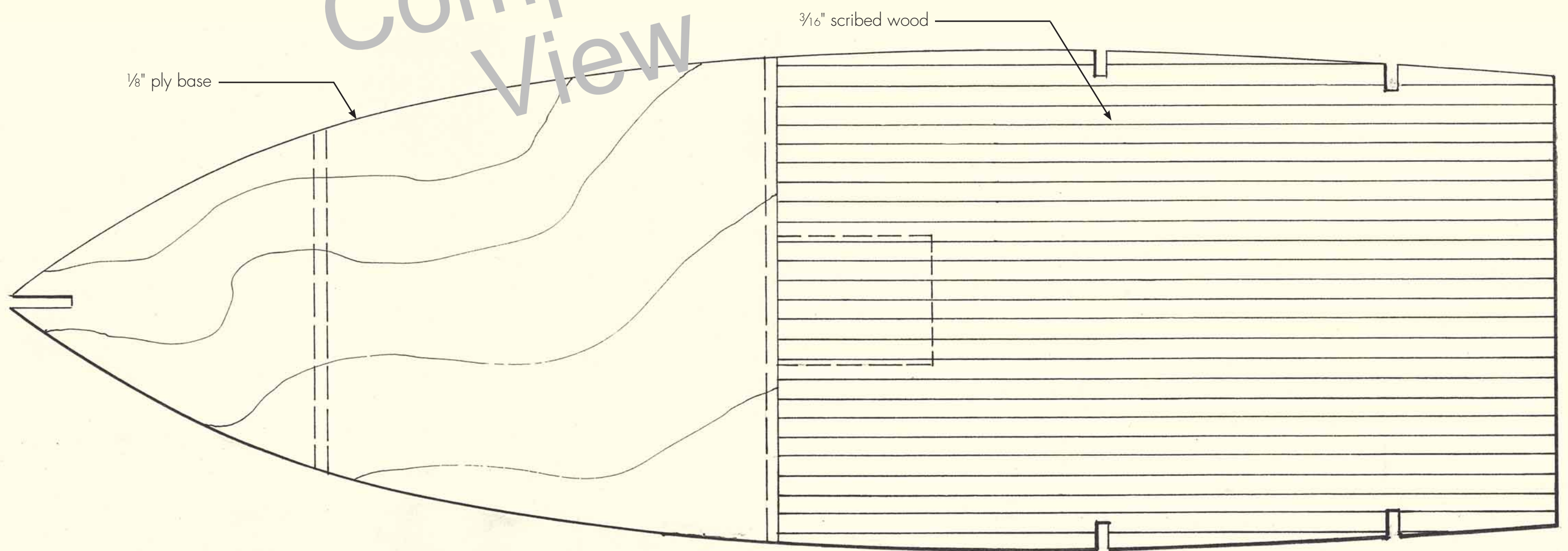

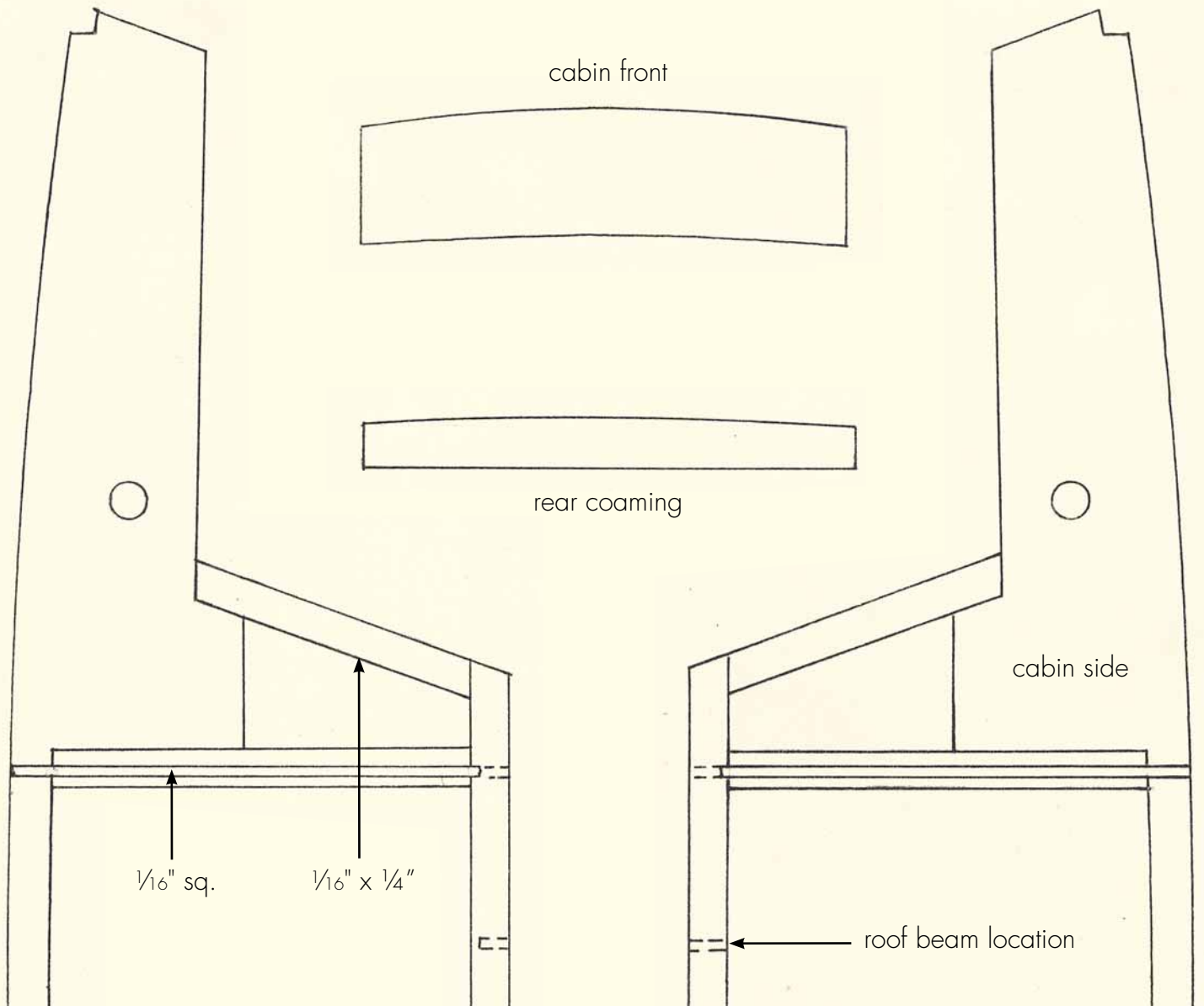
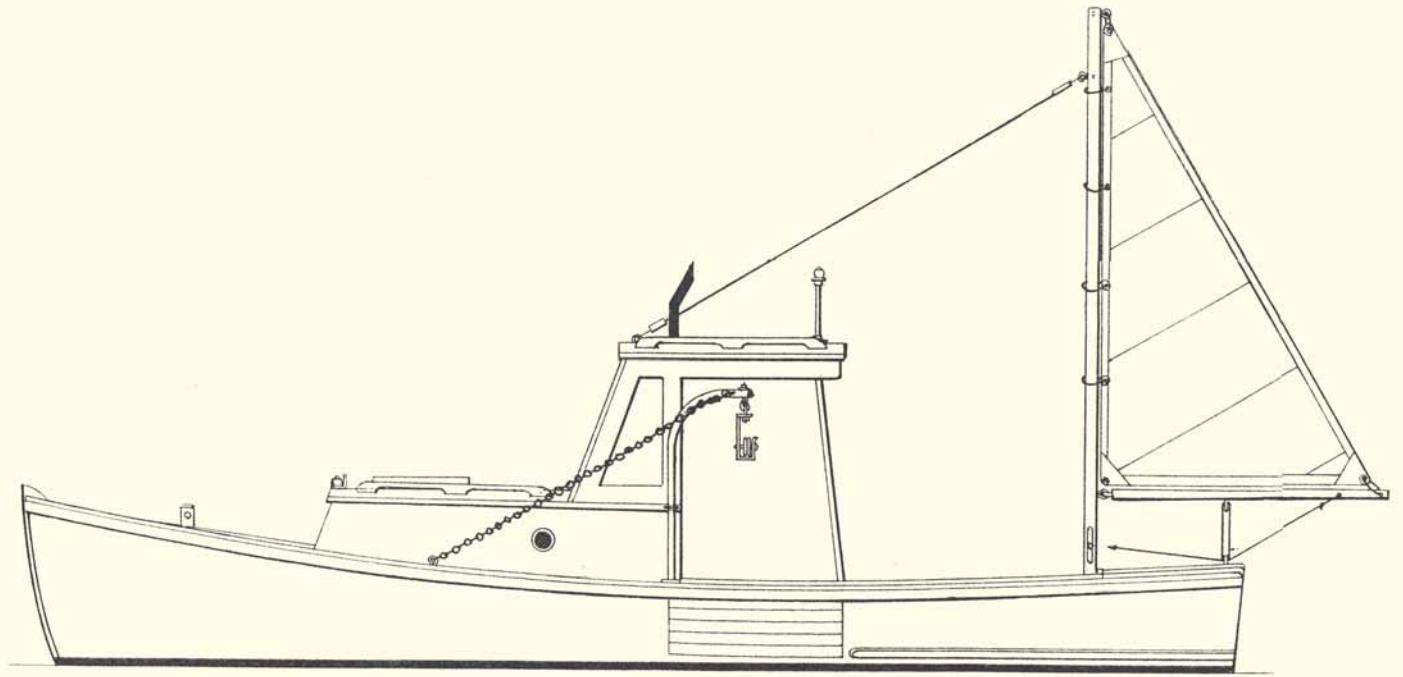

# 1:20.3-scale lobster boat (waterline model), part 1: basic boat

by Ted Stinson | Wiscasset, Maine



Lobstering became a profitable industry in the 20th century, served by boats that evolved along with the industry and the availability of internal-combustion engines, lobsters were not considered a great delicacy and the industry moved on from sailing sloops, such as the Friendship sloop. After WWI came cars, roads, and tourists, and lobsters became a big catch. Small, wooden boats with modified automobile engines became the standard vessel to serve the industry. This is the lobster boat.

In the 1960s, two things happened that greatly influenced the industry. Fiberglass boats and the interstate highway system led to bigger markets, bigger boats, and bigger catches. Those excesses led to the present over-fished conditions.

Finding an example of an earlier, wooden boat for these plans was not easy. As it turned out, I found two, not in the best of condition but still maintained with some care. Also, I decided that a waterline model made the most sense. I wanted a model that would look like a full-size wooden boat—possibly unloading its catch. I did not want to leave a model boat floating in a pond, exposed to rain and UV light. The maintenance of a full-size wooden boat is bad enough; maintenance of a model would be far worse. A simple, submerged display on a couple of bricks, will give you something to set the model on. Also, it is much easier to build a waterline model.

This will be a three-part series. This first part will let you build the basic boat, the second will show you how to build a dock, and the third will let you build a dock with a lobstering shack.

## Construction

Refer to the plan. From a piece of  $\frac{1}{8}$ " x 5" x 15" plywood, cut the base. Mark the location of F1 & F2. Using  $\frac{1}{32}$ " scribed wood, surface the cockpit area shown on the plan. Use contact cement (such as used in gluing Formica to a table) to your liking (we used Golden Oak) and apply two coats of clear lacquer to the deck. Now, using  $\frac{1}{8}$ "-thick balsa, glue in place the Stem, F1, F2, F3, and the Transom. Before gluing F2, F3, and the Transom in place, give them a couple of coats of clear white, water-base acrylic. Mark the ink-line door on F2 at this time. Now glue these items to the base.

Make up the motor box, which is a  $\frac{3}{4}$ " x  $1\frac{1}{4}$ " x  $1\frac{1}{2}$ " block, paint it white, and glue it in place. Now cut out the motor box from  $\frac{3}{32}$ "-thick balsa. Glue these together along the centerline. Fit and glue the deck in place on the Frame head using  $\frac{1}{8}$ " x  $\frac{1}{4}$ " strips. These will need to be painted white prior to gluing them in place. Now, sand the edges of the

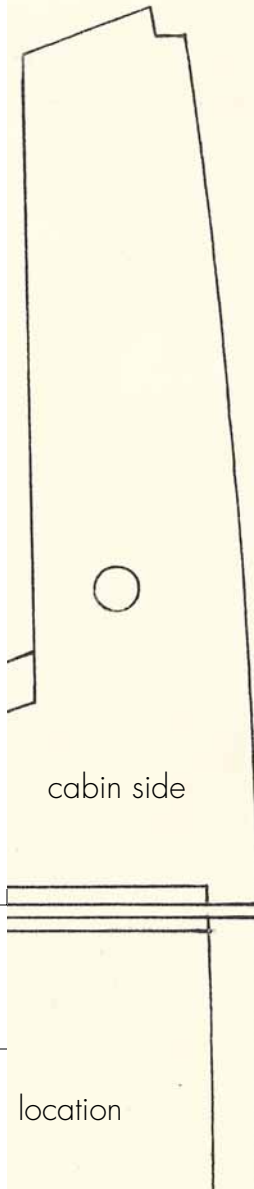
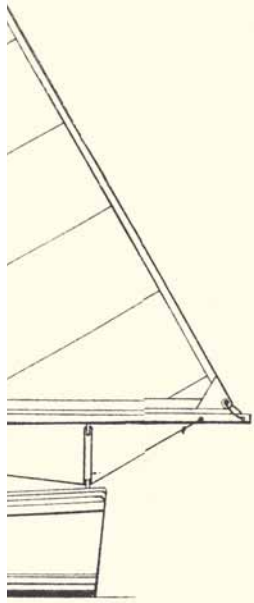

Plan set #77-A

# Basic boat



evolved along with the industry. Before WWI  
 a great delicacy and the industry was carried  
 and tourists, and lobsters became a valuable  
 vessel to serve the industry. This is such a

ss boats and the interstate highway system led  
 nt over-fished conditions.

ned out, I found two, not in the water, of course,  
 most sense. I wanted a model that was next to a  
 pond, exposed to rain and UV radiation. Mainte-  
 worse. A simple, submerged support, such as a  
 build a waterline model.

he second will show you how to detail it, and

ocation of F1 & F2. Using  $\frac{1}{32}$ " thick,  $\frac{3}{16}$ "-spaced  
 s used in gluing Formica to a shelf) for this. Stain  
 the deck. Now, using  $\frac{1}{8}$ "-thick balsa, cut out the  
 them a couple of coats of clear lacquer, followed  
 these items to the base.

glue it in place. Now cut out two deck halves  
 k in place on the Frame heads. Finally, add the  
 Now, sand the edges of the hull fair in prepara-

1/16" sq.

1/16" x 1/4"

roof beam location

F2

ink line

roof beams

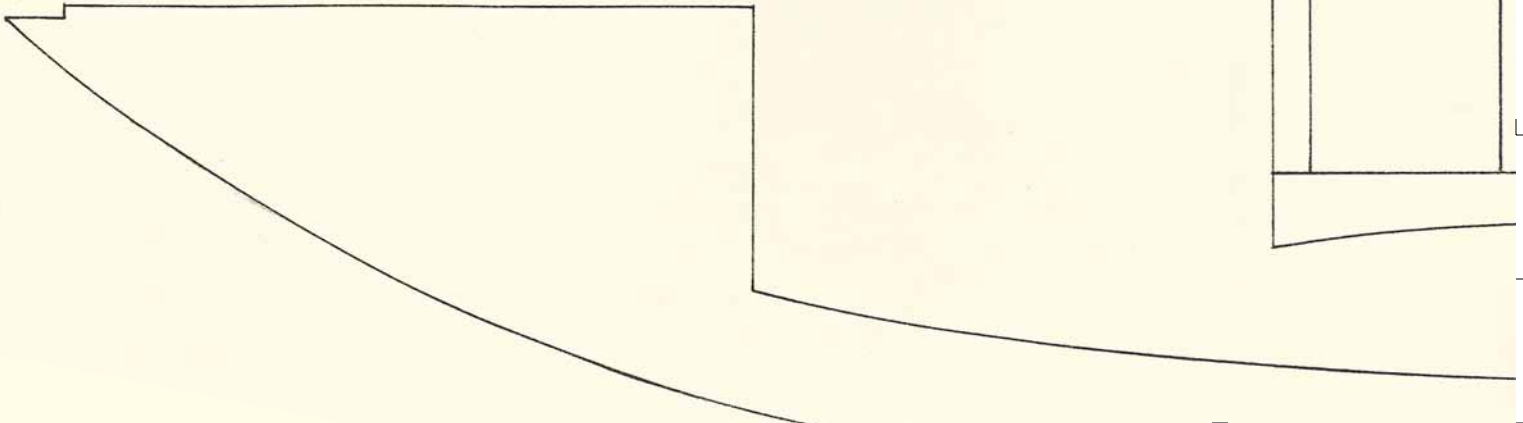

### Construction

Refer to the plan. From a piece of 1/8" x 5" x 15" plywood, cut the base. Mark the location of F1 & F2. Using 1/32 scribed wood, surface the cockpit area shown on the plan. Use contact cement (such as used in gluing Formica to a this deck to your liking (we used Golden Oak) and apply two coats of clear lacquer to the deck. Now, using 1/8"-thick Stem, F1, F2, F3, and the Transom. Before gluing F2, F3, and the Transom in place, give them a couple of coats of clear by flat white, water-base acrylic. Mark the ink-line door on F2 at this time. Now glue these items to the base.

Make up the motor box, which is a 3/4" x 1 1/4" x 1 1/2" block, paint it white, and glue it in place. Now cut o from 3/32"-thick balsa. Glue these together along the centerline. Fit and glue the deck in place on the Frame hea 1/8" x 1/4" strips. These will need to be painted white prior to gluing them in place. Now, sand the edges of the l tion for planking.

Use 1/32" plywood for planking. It is tough and waterproof. First, make a planking pattern using file-folder wood slightly oversize. When fitting the planking in place, try to get the edge of the planking flush with the top You will find it much easier to remove excess plywood from the bottom rather than the deck surface. Remove a from the hull. Now glue a 1/16" x 1/8" strip at the bow (the gripe). Sand this smooth and fair with the hull.

Now cut out the Cabin parts from firm, 1/16" balsa. Protect the plan with wax paper. Make up the cabin s shield. Fit and glue the cabin sides in place first, followed by the cabin front and the rear coaming. The cabin i cut and fitted in place. Use file-folder material to make a pattern, then cut the roof from 1/16" x 4" balsa. Once and glue the windshield in place, followed by the roof beams. Make up the shelter roof but don't glue it in plac

Fill any irregularities in the deck with spackle and sand smooth with 220-grit sandpaper. Using basswood c the 1/16"-square toerail in place, followed by the 1/16" x 1/8" rub rail and the 1/8"-square spray rail. Now give any finished, two coats of clear lacquer. This should be followed by two brush coats of flat-white acrylic (the hull v

When dry, fit and glue the shelter roof in place and give it a similar finish treatment. At this point the dec painted a color of your choice. Buff or light gray would be typical. The whole model can now be given a lig lacquer to seal it and protect it from fingerprints, etc.

At this point the model is ready for detailing, which will be covered in the next installment.

\* \* \*

This sheet is a supplement to the June 2006 issue of *Garden Railways* magazine. While supplies last, extra cc ings can be had by sending \$1.50 per set (\$2.00 foreign) to: Sidestreet Bannerworks, PO Box 460222, Denver complete list of available plans can be found at [www.sidestreet.info](http://www.sidestreet.info), or send a stamped, self-addressed env address.

A complete kit for this project (including appropriate details) is available from Northeast Narrow Gauge for \$ from Northeast Narrow Gauge, PO Box 191, Wiscasset ME 04578. Web site: [www.nemodel.com](http://www.nemodel.com)

© 2006 by Garden Railways and Northeast Narrow Gauge. These drawings may be photocopied by individua own personal use. Copying for any commercial use or for distribution is prohibited without written consent fro

### Are you working in a different scale?

- If you are working in 1:32 scale, reduce these drawings to 63
- If you are working in 1:29 scale, reduce these drawings to 70
- If you are working in 1:24 scale, reduce these drawings to 83
- If you are working in 1:22.5 scale, reduce these drawings to 91
- If you are working in 16mm scale, enlarge these drawings to 150
- If you are working in 1:13.7 (7/8") scale, enlarge these drawings to 225

windshield

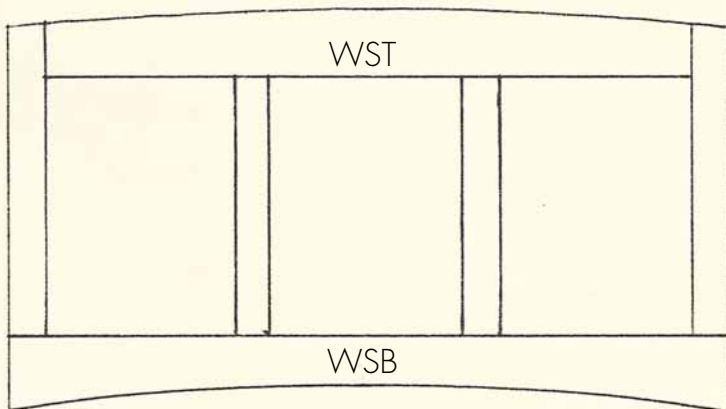

location

ocation of F1 & F2. Using 1/32" thick, 3/16"-spaced  
s used in gluing Formica to a shelf) for this. Stain  
the deck. Now, using 1/8"-thick balsa, cut out the  
them a couple of coats of clear lacquer, followed  
these items to the base.

glue it in place. Now cut out two deck halves  
k in place on the Frame heads. Finally, add the  
Now, sand the edges of the hull fair in prepara-

ng pattern using file-folder stock. Cut the ply-  
planking flush with the top of the deck (sheer).  
the deck surface. Remove any excess planking  
and fair with the hull.

paper. Make up the cabin sides and the wind-  
e rear coaming. The cabin roof should now be  
from 1/16" x 4" balsa. Once the roof is done, fit  
roof but don't glue it in place yet.

ndpaper. Using basswood or pine, fit and glue  
are spray rail. Now give any wood not already  
flat-white acrylic (the hull was white).

ment. At this point the deck should be brush-  
del can now be given a light dusting of clear

nstallment.

While supplies last, extra copies of these draw-  
ks, PO Box 460222, Denver CO 80246 USA. A  
amped, self-addressed envelope to the above

rtheast Narrow Gauge for \$50 + \$8 s&h. Order  
*emodel.com*

e photocopied by individual modelers for their  
without written consent from the publisher.

## nt scale?

- reduce these drawings to 63 %.
- reduce these drawings to 70 %.
- reduce these drawings to 88 %.
- e, reduce these drawings to 90 %.
- e, enlarge these drawings to 107 %.
- ) scale, enlarge these drawings to 148 %.

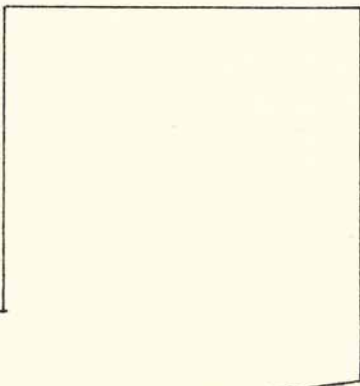



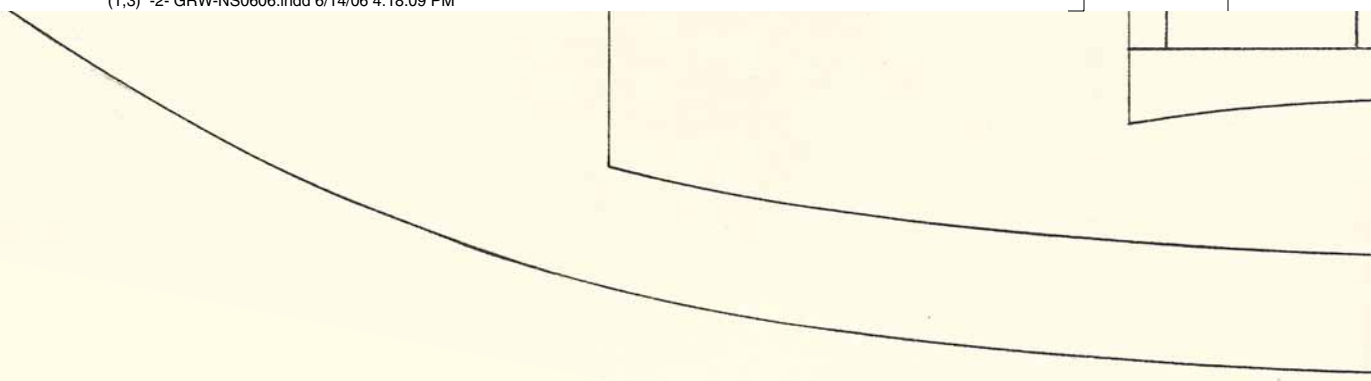

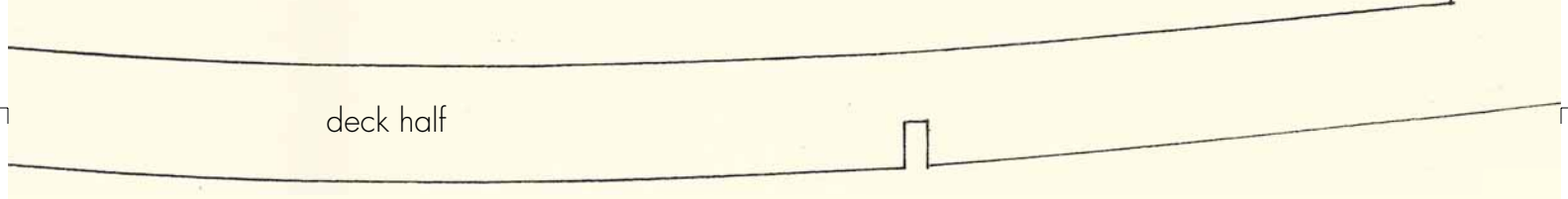
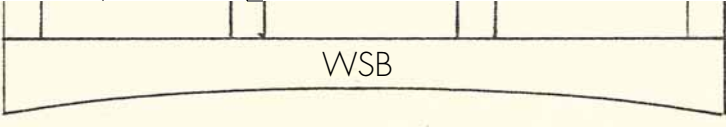

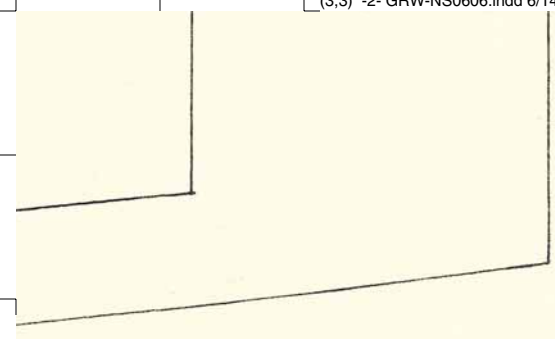

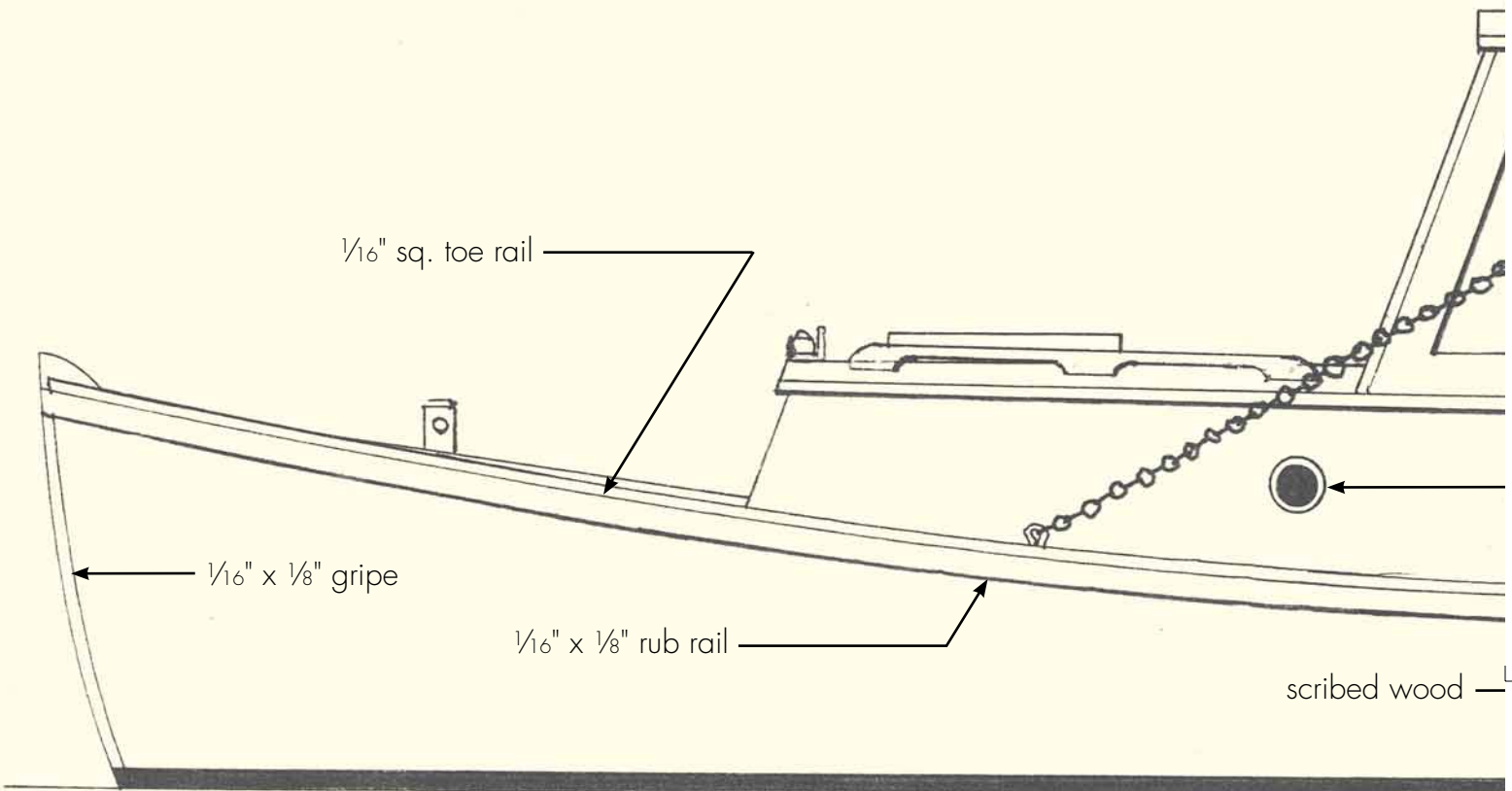
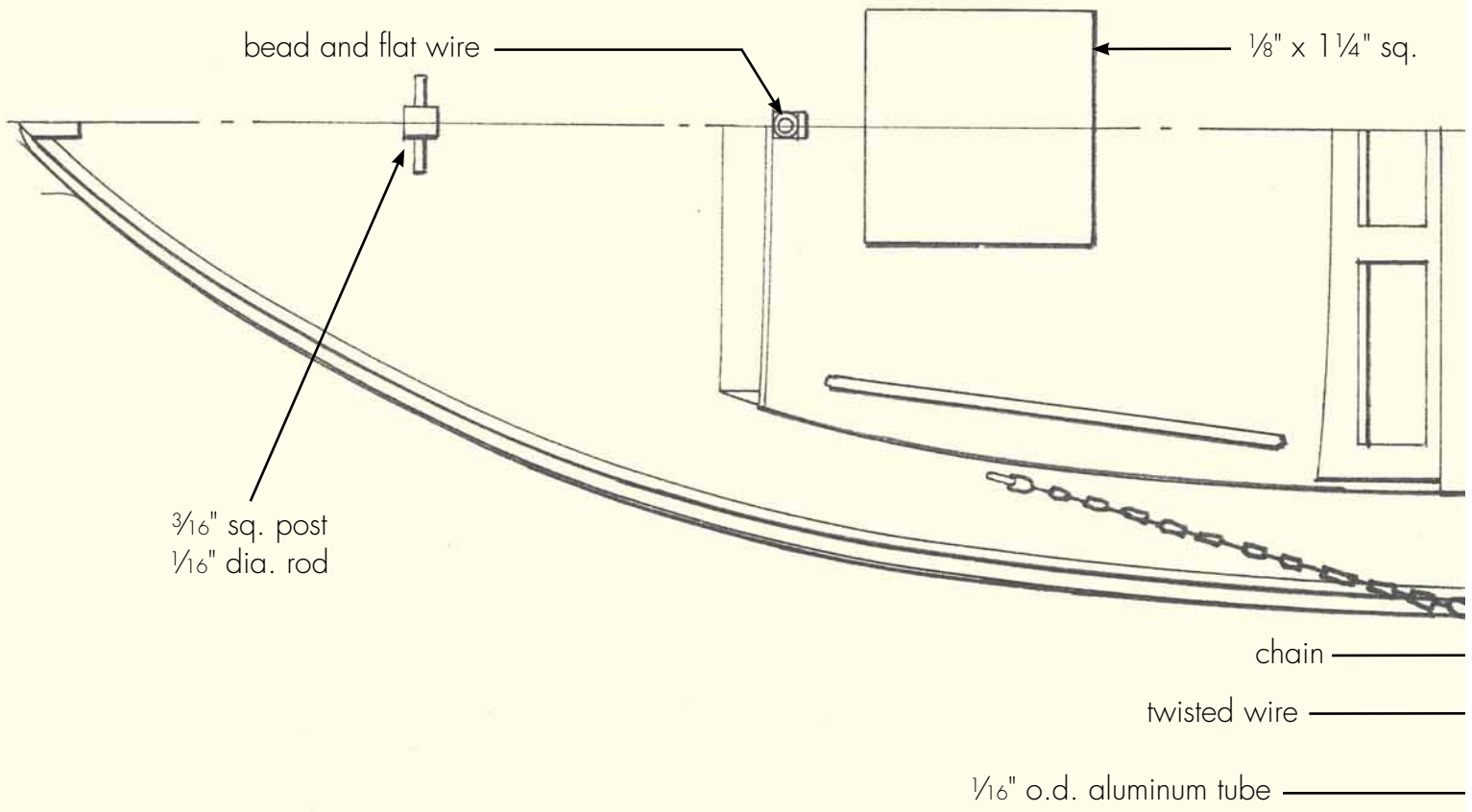

— 1/8" x 1 1/4" sq.

exhaust—1/8" dia. dowel

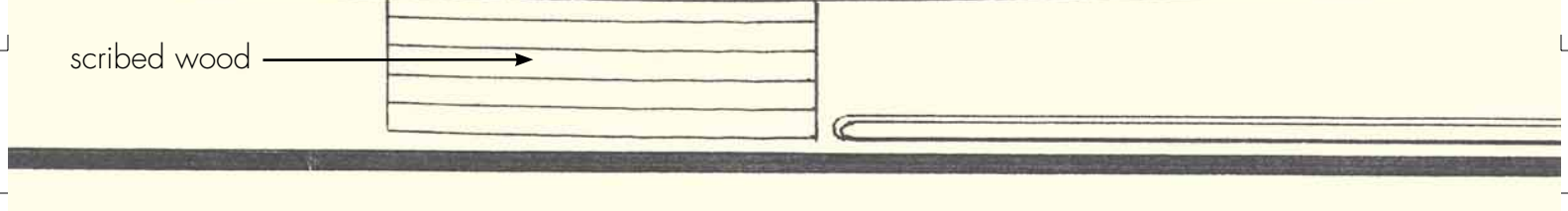
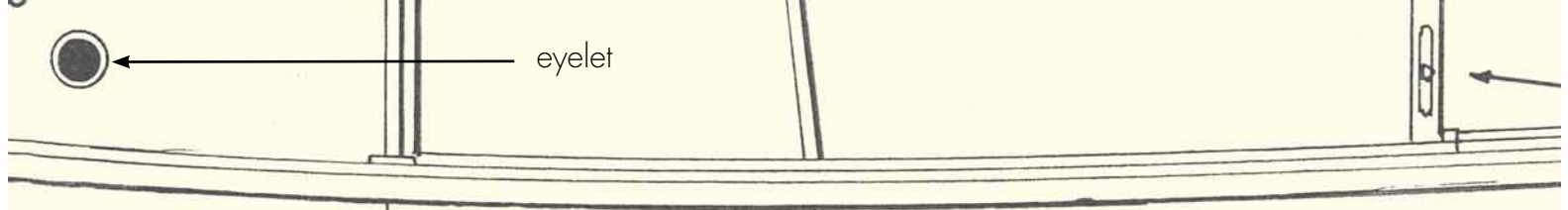
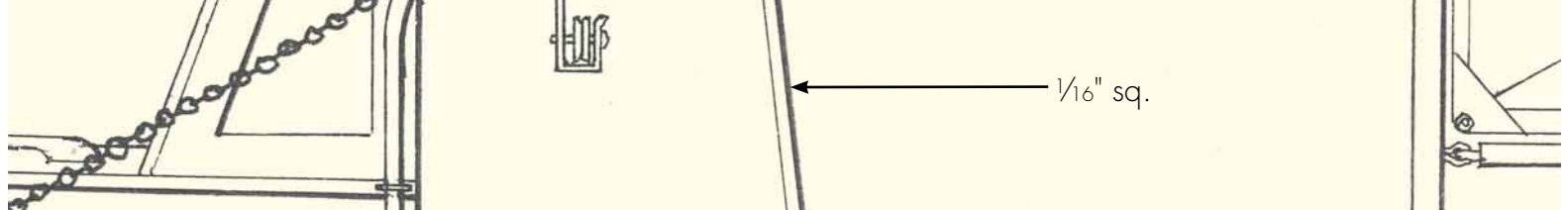
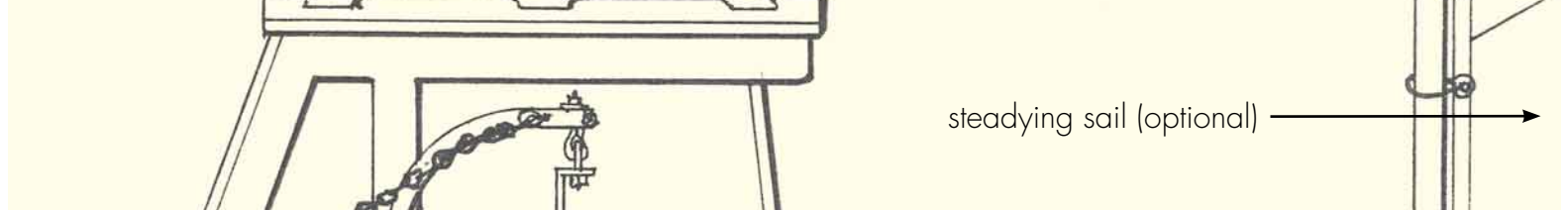
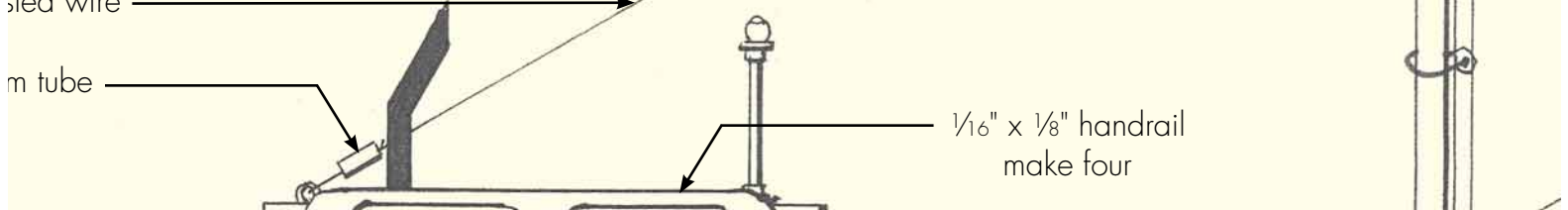
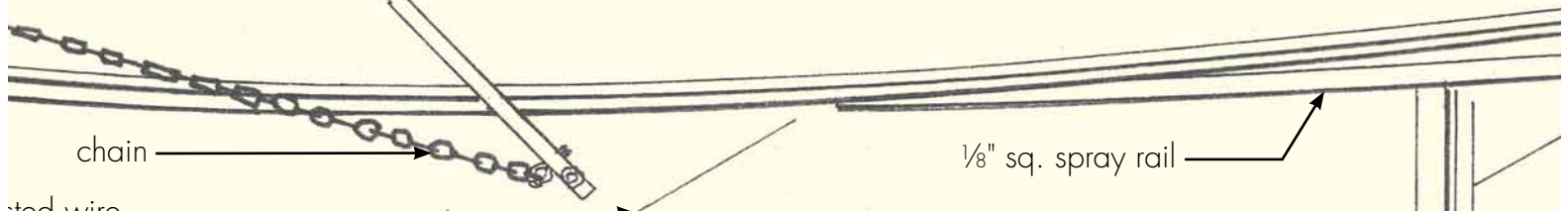
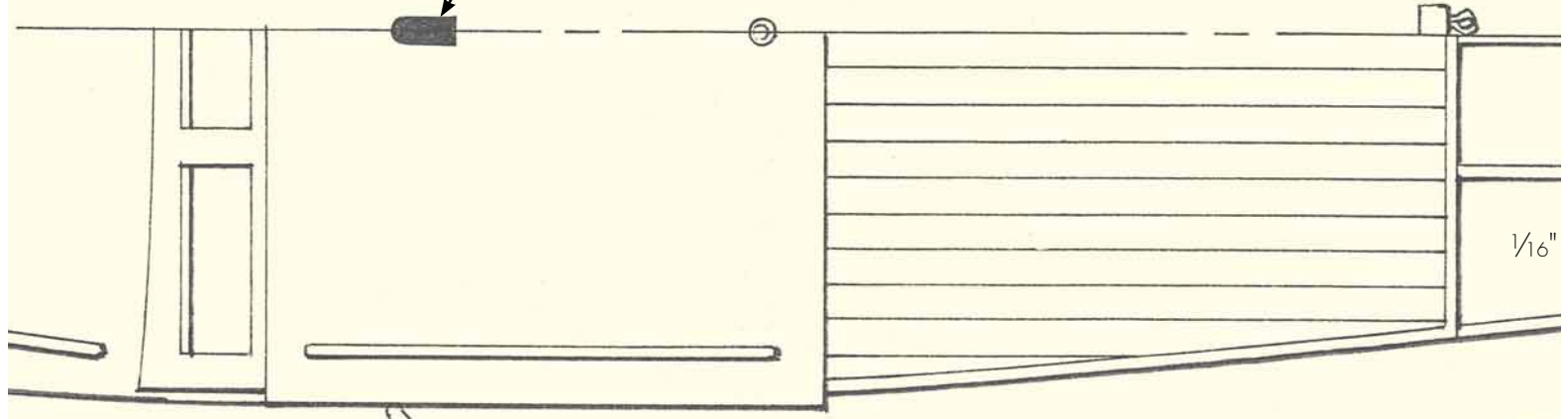

chain

1/8" sq. spray rail

stead wire

1/16" x 1/8" handrail  
make four

stead tube

steadying sail (optional)

1/16" sq.

eyelet

scribed wood

3/16" scribed wood

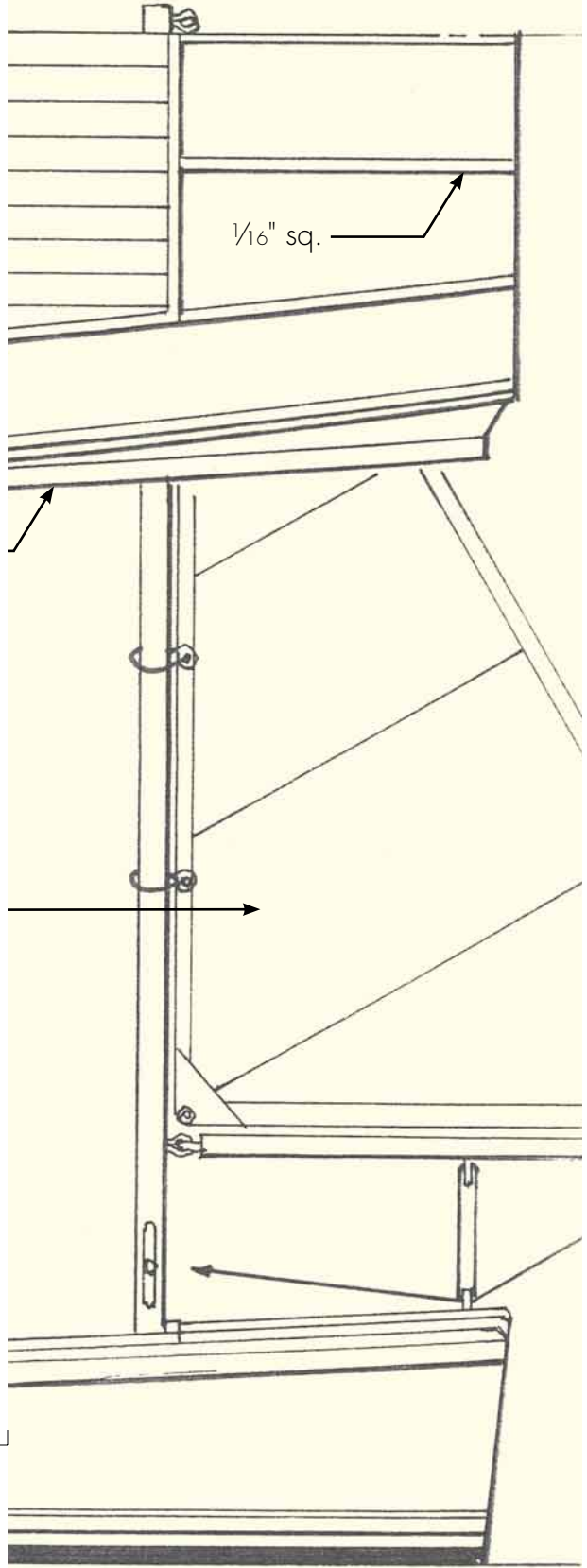

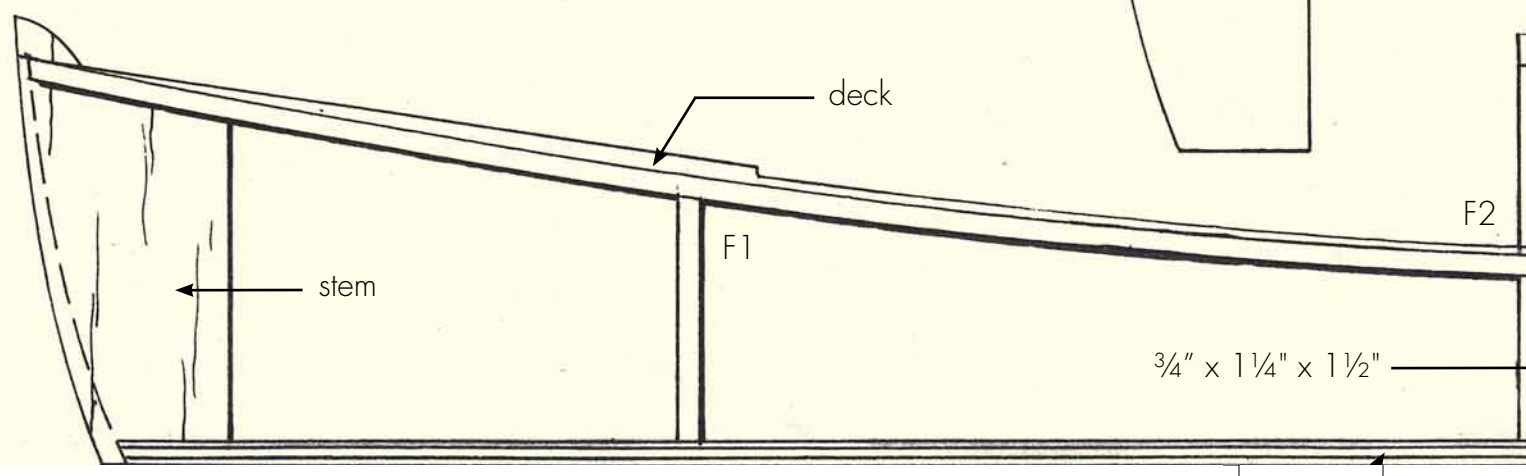
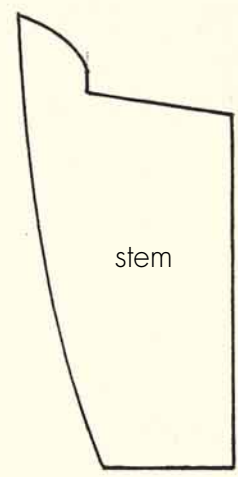
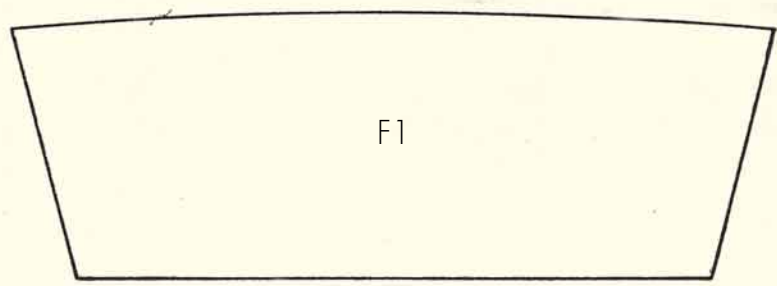
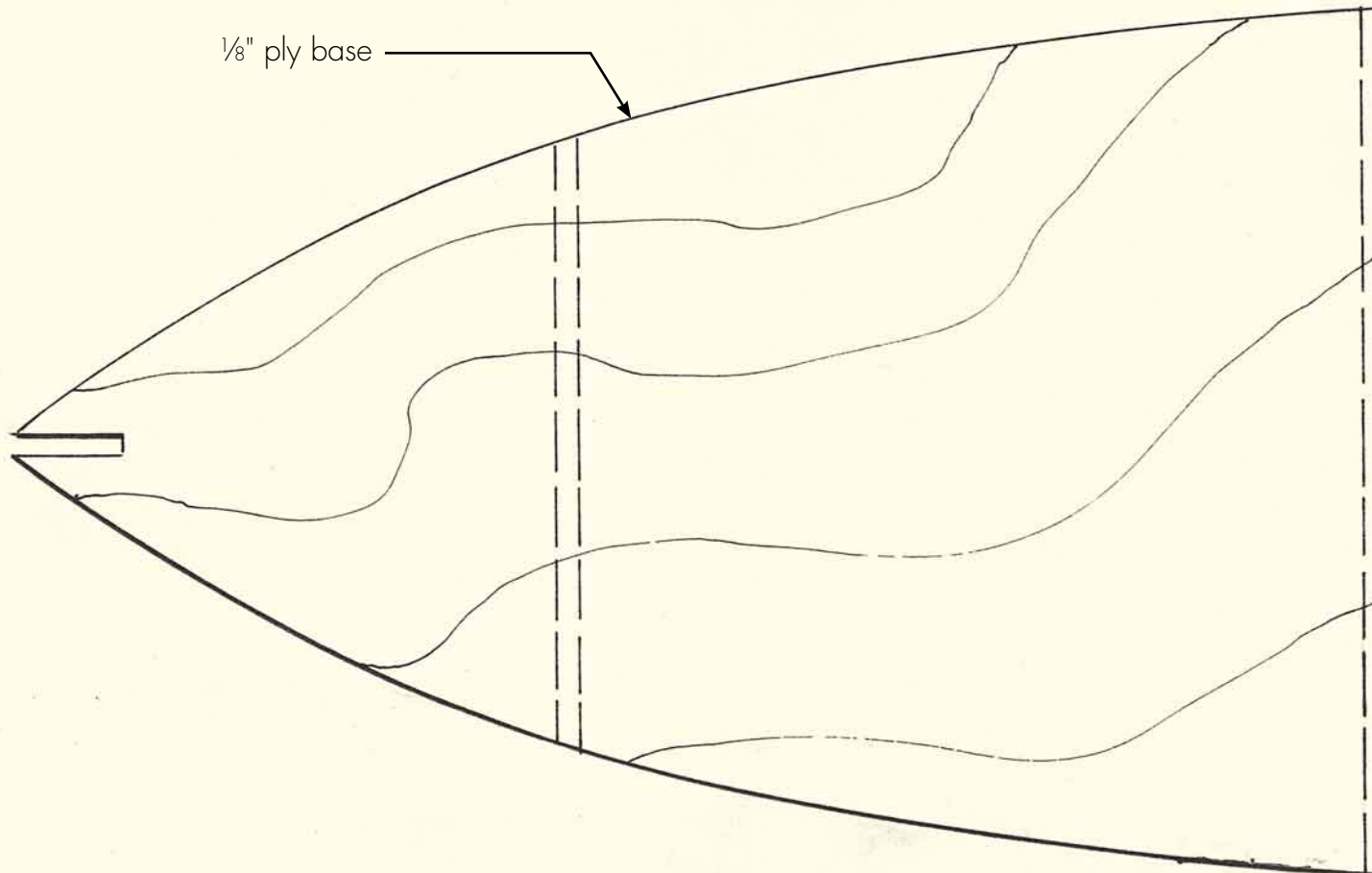

scribed wood

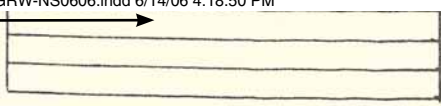

3/16" scribed wood

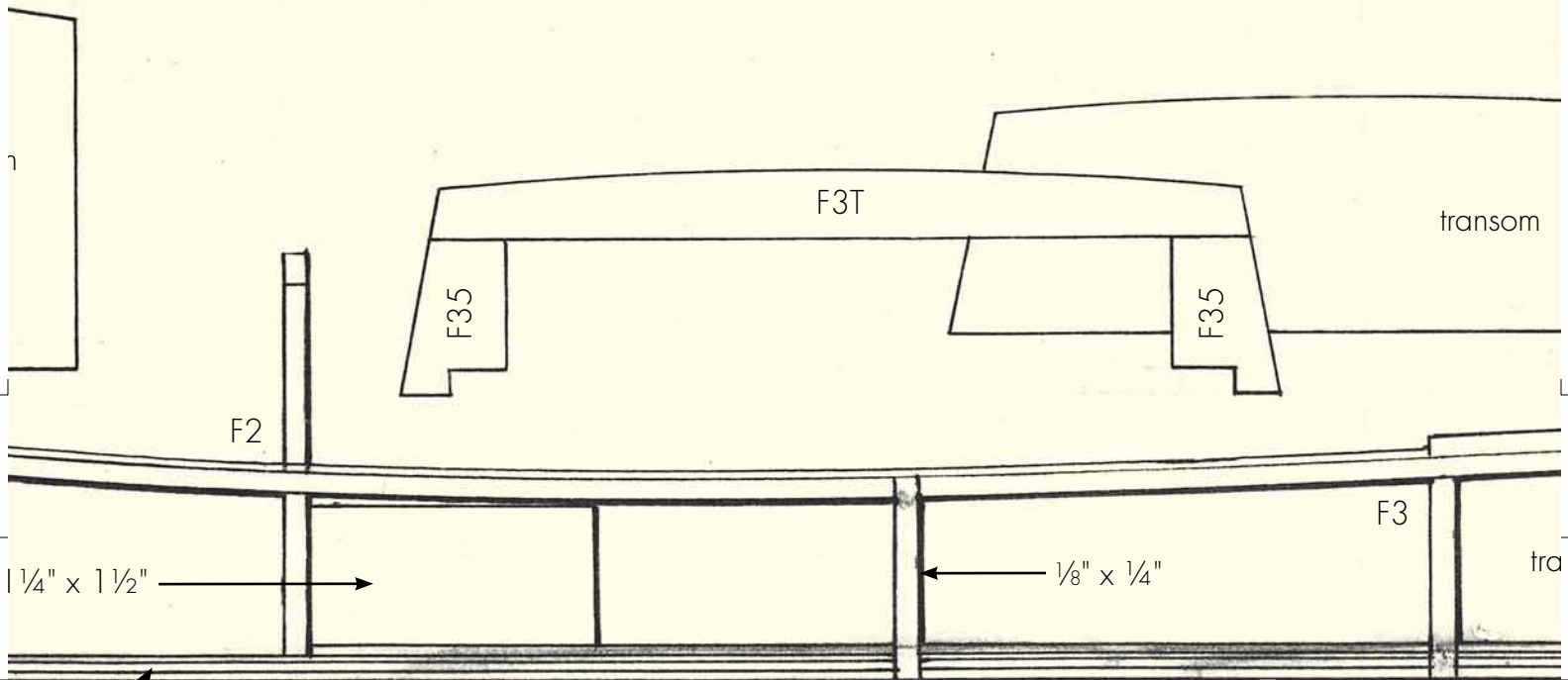
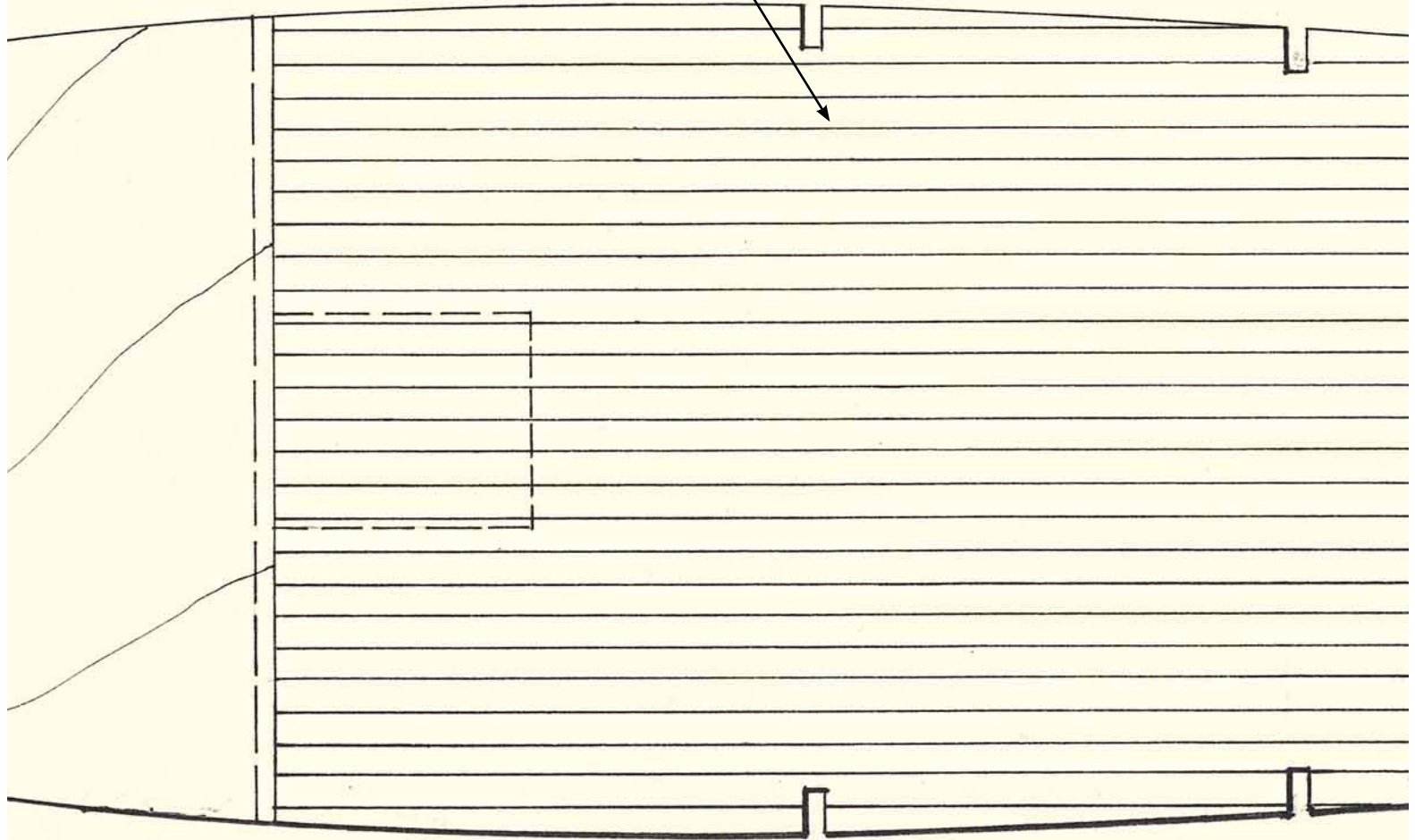



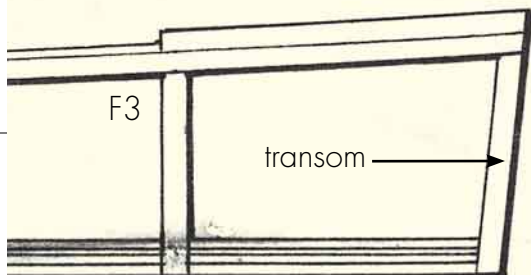
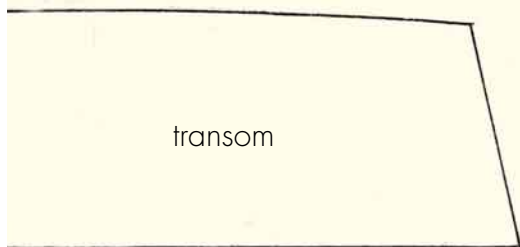
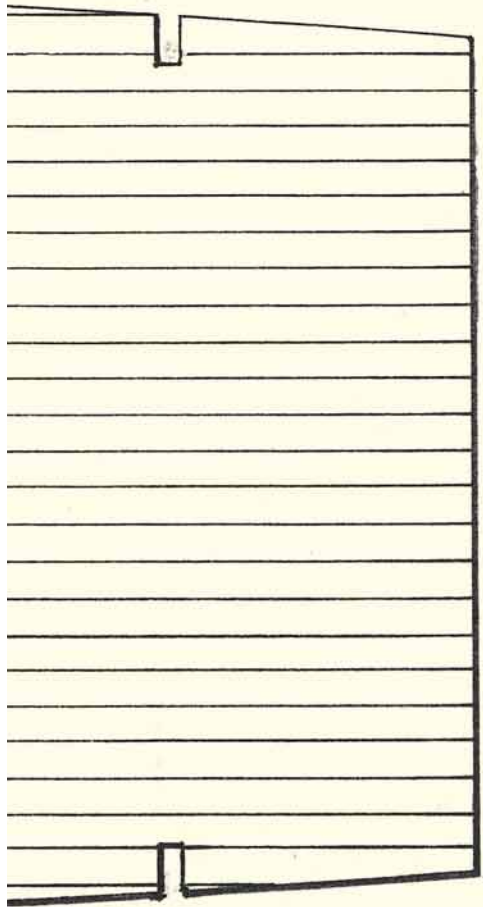
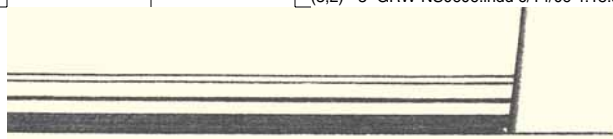

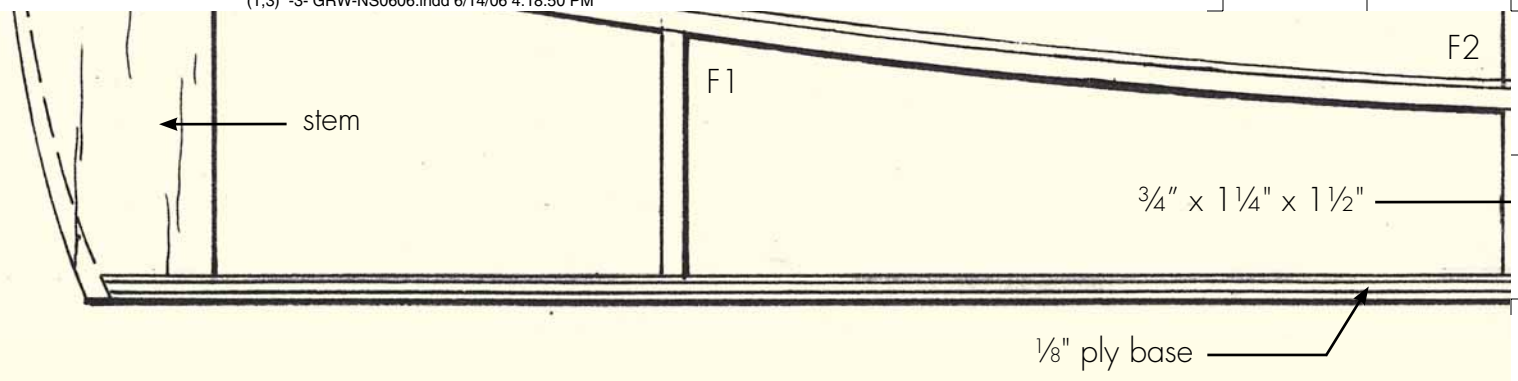

F2

F3

1 1/4" x 1 1/2" →

← 1/8" x 1/4"

tra

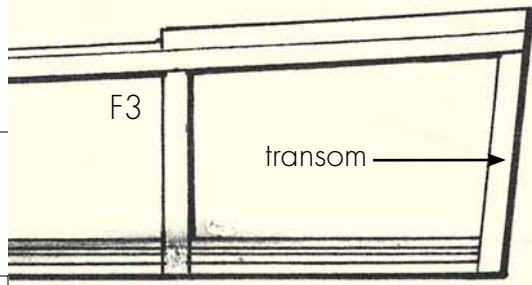

©2006 Northeast Narrow Gauge